

TECHNICAL SPECIFICATION SECTION-SWITCHYARD ERECTION



पावरग्रिड

पावर ग्रिड कॉर्पोरेशन ऑफ इंडिया लिमिटेड

(भारत सरकार का उद्यम)

Power Grid Corporation of India Limited

(A Government of India Enterprises)

TECHNICAL SPECIFICATION

**SECTION- SWITCHYARD ERECTION
REVISION - 10**

SECTION-(SE)
SWITCHYARD ERECTION

CONTENTS

Clause No	Particulars	Page No.
1.0	General	1
2.0	String Insulators & Hardware	1
3.0	AAC/ACSR Conductor	12
4.0	Galvanised Steel Earth Wire	15
5.0	Aluminium Tube	17
6.0	Earthing Conductors	18
7.0	Spacers	19
8.0	Bus Post Insulators	20
9.0	Earthing	23
10.0	Bus Bars	28
11.0	Bay Equipment	28
12.0	Lightning Protection	30
13.0	Equipment Erection Details	30
14.0	Storage	31
15.0	Cabling Material	31
16.0	Directly Buried Cables	33
17.0	Installation Of Cables	33
18.0	Junction Box	38
19.0	Testing And Commissioning	38
Annexure-A	Testing Procedure for ACSR MOOSE conductor	40
Annexure-B	Testing Procedure for Galvanised Steel Earthwire	42
Annexure-C	Corona and Radio Interference Voltage (RIV) Test	44
Annexure-D	Short Circuit Forces And Spacer Span for Gantry Str.	46
Annexure-E	Standard Technical Data Sheets for Conductors, Earthwire and Aluminium pipe	48

SECTION-(SE)
SWITCHYARD ERECTION

1.0 **GENERAL**

This section covers erection of all equipment such as circuit breakers, isolators, current transformers, voltage transformers, surge arresters etc. This section also covers design, engineering, manufacture, testing at works, supply, insurance, handling, storage, erection, testing and commissioning of supply & erection of following items.

- String insulators and hardware
- AAC / ACSR conductor
- Galvanised Steel Earthwire
- Aluminium Tube
- Spacers
- Bus post insulators
- Earthing & Earthing materials
- Lightning protection materials
- Cabling material
- Other items

2.0 **String Insulators & Hardware**

The insulators for suspension and tension strings shall conform to IEC-60383 and long rod insulators shall conform to IEC-60433. Insulator hardware shall conform to IS:2486. Composite long rod polymer insulator shall conform to IEC:61109. Further, the contractor shall supply insulators as per details mentioned below:

A. Tension Insulator String

Sl. No.	System Voltage	Type
1.	765kV, 400kV, 220kV & 132kV (for all substations in coastal, pollution affected areas as identified in Section-Project and for all substations in Northern Region)	Composite Long Rod Polymer with 31mm/kV Creepage
2.	765kV, 400kV, 220kV & 132kV (for substations not covered in 1. above)	Composite Long Rod Polymer/Porcelain/Glass with 31mm/kV Creepage

B. Suspension Insulator String

Sl. No.	System Voltage	Type
1.	765kV, 400kV, 220kV & 132kV (for all substations)	Composite Long Rod Polymer with 31mm/kV Creepage

SECTION - (SE) **SWITCHYARD ERECTION**

2.1 Construction Features (Porcelain & Glass Insulators)

2.1.1 Porcelain insulators

- a) Suspension and tension insulators shall be wet process porcelain with ball and socket connection. Insulators shall be interchangeable and shall be suitable for forming either suspension or tension strings. Each insulator shall have rated strength, manufacturer's logo, month & year of manufacturing markings on porcelain printed and applied before firing.
- b) Porcelain used in insulator manufacturing shall be homogeneous, free from laminations, cavities and other flaws or imperfections that might affect the mechanical or dielectric quality and shall be thoroughly vitrified, tough and impervious to moisture.
- c) Glazing of the porcelain shall be of uniform brown colour, free from blisters, burrs and other similar defects.

2.1.2 Glass insulators

It **shall** be made of toughened glass. Glass used for the shells shall be sound, free from defects, flows bubbles, inclusions, etc and be of uniform toughness over its entire surface. All exposed glass surfaces shall be smooth.

2.1.2.1 When operating at normal rated voltage, there shall be no electric discharge between conductor and insulator which would cause corrosion or **damage** to conductors or insulators by the formation of substances due to chemical action.

2.1.2.2 The design of the insulator shall be such that stresses due to expansion and contraction in any part of the insulator shall not lead to deterioration. All ferrous parts shall be hot dip galvanized in accordance with the latest edition of IS: 2629. The zinc used for galvanizing shall be of grade Zn-99.95 as per IS-209. The zinc coating shall be uniform, adherent, smooth, reasonably bright, continuous and free from imperfections such as flux, ash, rust stains bulky white deposits and blisters.

2.1.2.3 Contractor shall make available data on all the essential features of design including the method of assembly of discs and metal parts, number of discs per insulator string, the manner in which mechanical stresses are transmitted through discs to adjacent parts, provision for meeting expansion stresses, results of corona and thermal shock tests, recommended working strength and any special design or arrangement employed to increase life under service conditions.

2.1.3 Hardware Fittings

2.1.3.1 Clamps for insulator strings and Corona Control rings shall be of aluminium alloy as stipulated for clamps and connectors.

2.1.3.2 Insulator hardware shall be of forged steel. Malleable cast iron shall not be accepted except for insulator disc cap. The surface of hardware must be clean, smooth, without cuts, abrasion or projections. No part shall be subjected to excessive localized pressure. The metal parts shall not produce any noise generating corona under operating conditions.

2.1.3.3 The tension Insulator hardware assembly shall be designed for minimum 21000 kg tensile load for 765kV and minimum 12000 kg tensile load for hardware

SECTION - (SE) **SWITCHYARD ERECTION**

assembly below 765kV. Earth wire tension clamp shall be designed for minimum 1000 kg tensile load with a factor of safety of two (2).

2.1.3.4 The tension string assemblies shall be supplied alongwith suitable turn buckle. Sag compensation springs if required may also be provided.

2.1.3.5 All hardware shall be bolted type.

2.2 Tests

In accordance with the stipulations of the specification, the suspension and tension strings, insulator and hardware shall be subjected to the following type tests, acceptance tests and routine tests:

2.2.1 Type Tests on Insulator Strings: The test reports for following type tests shall be submitted for approval as per clause 9.0 of Section - GTR.

- a) Power frequency voltage withstand test with corona control rings (**if applicable**) under wet condition as per IEC- 60383.
- b) Switching surge voltage withstand test [400 kV and above class only] under wet condition as per IEC-60383.
- c) Lightning Impulse voltage withstand test with corona control rings under dry condition as per IEC-60383
- d) Voltage distribution test (Dry) [**applicable for disc insulator string only**]

The voltage across each insulator unit shall be measured by sphere gap method. The result obtained shall be converted into percentage. The voltage across any disc shall not exceed 6.5% for 765 kV suspension and tension insulator strings, 9% and 10% for 400KV suspension string and tension insulator string respectively, 13% for 220KV suspension and tension insulator strings, 20% and 22% for 132KV suspension and tension insulator strings respectively.

- e) Corona Extinction Voltage test (Dry) [**220kV** and above class only]

The sample assembly when subjected to power frequency voltage shall have a corona extinction voltage **as specified at clause 2.3.2**. There shall be no evidence of Corona on any part of the sample. The atmospheric condition during testing shall be recorded and the test results shall be accordingly corrected with suitable correction factor as stipulated in IEC 60383.

- f) RIV Test (Dry) [**220kV** and above class only]

Under the conditions as specified under (e) above the insulator string alongwith complete hardware fittings shall have a radio interference voltage as **specified in clause 2.3.2 of this section**. The test procedure shall be in accordance with IS 8263/IEC 60437.

- g) Mechanical strength test: The test shall be carried out as per following procedure.

SECTION - (SE) **SWITCHYARD ERECTION**

The complete insulator string alongwith its hardware fitting excluding arcing horn, corona control ring, grading ring, tension/suspension clamps shall be subjected to a load equal to 50% of the specified minimum ultimate tensile strength (UTS) which shall be increased at a steady rate to 67% of the minimum UTS specified. The load shall be held for five minutes and then removed. After removal of the load, the string components shall not show any visual deformation and it shall be possible to dismantle them by hand. Hand tools may be used to remove cotter pins and loosen the nuts initially. The string shall then be reassembled and loaded to 50% of UTS and the load shall be further increased at a steady rate till the specified minimum UTS and held for one minute. No fracture should occur during this period. The applied load shall then be increased until the failing load is reached and the value recorded.

2.2.2 Type Tests on String Insulator Units

Type test report for Thermal Mechanical Performance tests (**applicable for porcelain type insulators**) as per IEC-60575, Clause 3 shall be submitted for approval as per clause 9.2 of Section - GTR.

2.2.3 Acceptance Tests for Insulators:

- a) Visual examination as per IEC-60383/ IEC-61109 clause no. 7.2 (for composite long rod insulators).
- b) Verification of Dimensions as per IEC- 60383.
- c) Temperature cycle test as per IEC- 60383.
- d) Puncture Test as per IEC-60383 (Applicable only for porcelain insulators).
- e) Galvanizing Test as per IEC- 60383.
- f) Mechanical performance test as per IEC-60575 Cl. 4 / IEC-61109 clause no. 7.2 (for composite long rod insulators).
- g) Test on locking device for ball and socket coupling as per IEC-60372(2).
- h) Porosity test as per IEC- 60383 (Applicable only for porcelain insulators).
- i) Thermal shock test as per IEC-60383 (Applicable only for glass insulators)

2.2.4 Acceptance Test on Hardware Fitting

- a) Visual Examination as per Cl. 5.10 of IS: 2486 (Part-I).
- b) Verification of Dimensions as per Cl. 5.8 of IS:2486 (Part-I)
- c) Galvanising/Electroplating tests as per Cl. 5.9 of IS:2486 (Part-I).
- d) Slip strength test as per Cl 5.4 of IS-2486 (part-I)
- e) Shore hardness test **by** the Elastometer

SECTION - (SE) **SWITCHYARD ERECTION**

- f) Mechanical strength test for each component (including corona control rings and arcing horns).

The load shall be so applied that the component is stressed in the same way as it would be in actual service and the procedure as given in 2.2.1.(g) above should be followed.

- g) Test on locking devices for ball and socket coupling as per IEC -60372(2).

2.2.5 Routine Test on Insulator

- a) Visual Inspection as per IEC-60383
b) Mechanical Routine Test as per IEC-60383
c) Electrical Routine Test as per IEC-60383

2.2.6 Routine Test on hardware Fittings

- a) Visual examination as per Cl 5.10 of IS:2486 (Part-I)
b) Mechanical strength Test as per Cl. 5.11 of IS:2486 (Part-I)

2.2.7 Test during manufacture on all Components as applicable on insulator

- a) Chemical analysis of zinc used for galvanising: Samples taken from the zinc ingot shall be chemically analyzed as per IS: 209. The purity of zinc shall not be less than 99.95%.
b) Chemical Analysis, mechanical hardness tests and magnetic particle inspection for malleable casting:

The chemical analysis, hardness tests and magnetic particle inspection for malleable casting will be as per the internationally recognized procedures for these tests. The sampling will be based on heat number and heat treatment batch. The details regarding tests will be as discussed and mutually agreed to by the Contractor and Employer in Quality Assurance Program.

2.2.8 Test during manufacture on all components as applicable on hardware fittings:

- a) Chemical analysis of zinc used for galvanising:
Samples taken from the zinc ingot shall be chemically analyzed as per IS:209. The purity of zinc shall not be less than 99.95%
b) Chemical analysis, hardness tests and magnetic particle for Forgings/
fabricated hardware:

The chemical analysis, hardness tests and magnetic particle inspection for forgings/fabricated hardware will be as per the internationally recognized procedures for these tests. The sampling will be based on heat number and heat treatment batch. The details regarding tests will be as discussed and mutually agreed to by the Contractor and Employer in Quality Assurance Programme.

SECTION - (SE)
SWITCHYARD ERECTION

2.3 Guaranteed technical Particular For

2.3.1 Disc Insulators

Sl. No.	Description	For 765kV	For 400/220/132kV
a)	Type of insulators	Anti Fog type	Anti Fog type
b)	Physical Size of insulator units		
(i)	Diameter of Disc	As per IEC	As per IEC
(ii)	Ball to ball spacing between discs	170 mm	145 mm
c)	Electro mechanical strength	210 kN	120 kN
d)	Minimum Creepage distance of individual insulator units	460 mm	430 mm
e)	Markings		
i)	For Porcelain insulators	Markings on porcelain	Markings on porcelain
ii)	For toughened glass insulators	Markings shall be done on initial parts	Markings shall be done on initial parts
f)	Power frequency puncture withstand voltage	1.3 times the actual wet flashover voltage	1.3 times the actual wet flashover voltage

2.3.2 INSULATOR STRING

Sl. No.	Description	765 kV	400kV	220kV	132kV
a)	Power frequency withstand voltage of the complete string with corona control ring (wet) – KV rms	870	680	460	275
b)	Lightning impulse withstand Voltage of string with corona control rings (dry) - kVp	± 2100	± 1550	± 1050	± 650
c)	Switching surge withstand voltage of string with corona control rings (wet) - kVp	± 1550	± 1050	NA	NA
d)	Minimum corona extinction voltage level of string with Corona Control rings (dry) - kV rms	508	320	156	NA
e)	Maximum RIV level in micro volts of string with Corona Control rings across 300 Ohms resistor at 1 MHz	1000 (Max) at 508 kV	1000 (Max) at 320 kV	1000 (Max) at 156 kV	NA
f)	Minimum total creepage distance of the insulator string (mm)	24800	13020	7595	4495
g)	Minimum no. of discs per string (for tension string if applicable)	54	31	18	11

SECTION - (SE)
SWITCHYARD ERECTION

h)	Electromechanical strength of Insulator Unit. (KN)	210	120	120	120
----	---	-----	-----	-----	-----

For tension application:-

Double insulator strings for 765kV, 400kV, 220kV and single insulator strings for 132 kV systems shall be used.

For suspension application:-

V-type polymer insulator string shall be used for 765kV system and single suspension polymer insulator string shall be used for 400kV, 220kV & 132 kV systems.

2.4 COMPOSITE LONG ROD POLYMER INSULATOR

Bidder shall offer composite long rod polymer insulators with suitable hardware fittings.

2.4.1 Details of Composite Long Rod Insulators

2.4.1.1 Insulators shall have sheds of the “open aerodynamic profile without any under ribs” with good self-cleaning properties. Insulator shed profile, spacing projection etc. shall be strictly in accordance with the recommendation of IEC-60815.

2.4.1.2 Ball and socket shall be 20mm designation for 120kN & 24mm designation for 210kN Insulators in accordance with the standard dimensions stated in IEC:60120/ IS:2486 (Part-II). Insulators shall be interchangeable and shall be suitable for forming either suspension or tension strings. Each insulator shall have laser markings on housings for manufacturer’s name, month & year of manufacturing, rated strength markings on each composite insulator rod unit. No negative tolerance shall be applicable to creepage distance of composite insulators

2.4.1.3 **All ferrous parts shall be hot dip galvanized as per Section-GTR with minimum weight of zinc coating as 610 gm/sq.m for normal area and 900 gm/sq.m for coastal area as specified in Section-Project.**

2.4.2 Material

2.4.2.1 Core

It shall be a glass-fiber reinforced (FRP) epoxy resin rod of high strength. The rod shall be resistant to hydrolysis. The rod shall be of electrical grade corrosion resistant (ECR), boron free glass and shall exhibit both high electrical integrity and high resistance to acid corrosion.

2.4.2.2 Housing & Weathersheds

The FRP rod shall be covered by a sheath of a silicone rubber compound of a thickness of minimum **5mm**. The housing & weathersheds should have silicon content of minimum 30% by weight. It should protect the FRP rod against environmental influences, external pollution and humidity. It shall be extruded or directly molded on the core. The interface between the housing and the core must be uniform and without voids. The strength of the bond shall be greater than the tearing strength of the polymer. The manufacturer shall follow non-

SECTION - (SE) **SWITCHYARD ERECTION**

destructive technique (N.D.T.) to check the quality of jointing of the housing interface with the core.

The weathersheds of the insulators shall be of alternate shed profile. The weathersheds shall be vulcanized to the sheath (extrusion process) or molded as part of the sheath (injection moulding process) and free from imperfections. The vulcanization for extrusion process shall be at high temperature and for injection moulding shall be at high temperature & high pressure. Any seams/ burrs protruding axially along the insulator, resulting from the injection moulding process shall be removed completely without causing any damage to the housing. The track resistance of housing and shed material shall be class 1A4.5 according to IEC60587. The strength of the weathershed to sheath interface shall be greater than the tearing strength of the polymer. The composite insulator shall be capable of high pressure washing.

2.4.2.3 End Fittings

End fittings transmit the mechanical load to the core. They shall be made of malleable cast iron/ spheroidal graphite or forged steel. They shall be connected to the rod by means of a controlled compression technique. The manufacturer shall have in-process Acoustic emission arrangement or some other arrangement to ensure that there is no damage to the core during crimping. This verification shall be in-process and done on each insulator. The system of attachment of end fitting to the rod shall provide superior sealing performance between housing and metal connection. The gap between fitting and sheath shall be sealed by a flexible silicone rubber compound. The sealing shall stick to both housing and metal end fitting. The sealing must be humidity proof and durable with time.

End fittings shall have suitable provisions for fixing grading rings at the correct position as per design requirements.

2.4.2.4 Grading Rings

Grading rings shall be used at both ends of each composite insulator unit for reducing the voltage gradient on and within the insulator and to reduce TV noise to acceptable levels. The size and placement of the metallic grading rings shall be designed to eliminate dry band arcing/corona cutting/ exceeding of permissible electrical stress of material. The insulator supplier shall furnish design calculations using appropriate electric field software showing electric field at surface of housing, inside housing & core and at the interface of housing and metal fittings with the proposed placement and design of corona **rings**. Grading rings shall be capable of installation and removal with hot line tools without disassembling any other part of the insulator assembly.

The design & supply of grading rings shall be in the scope of the composite insulator supplier.

2.4.3 Tests

2.4.3.1 Type Tests

The test reports for following type tests on long rod units, components, materials or complete strings shall be submitted for approval as per clause 9.2 of Section - GTR.

SECTION - (SE) **SWITCHYARD ERECTION**

2.4.3.1.1 On the complete composite Long Rod Polymer Insulator String with Hardware Fittings:-

- a) Power frequency voltage withstand test with corona control rings/grading ring and arcing horns (if provided) under wet condition as per IEC:60383-1993.
- b) Switching surge voltage withstand test under wet condition as per IEC:60383-1993.
- c) Impulse voltage withstand test under dry condition as per IEC:60383-1993
- d) Corona and RIV test under dry condition. [132kV and above class only]

The sample assembly when subjected to power frequency voltage shall have a corona extinction voltage as specified in clause 2.3.2 of this section There shall be no evidence of Corona on any part of the sample. The atmospheric condition during testing shall be recorded and the test results shall be accordingly corrected with suitable correction factor as stipulated in IEC 60383.

Under the conditions as specified above the insulator string alongwith complete hardware fittings shall have a radio interference voltage level as specified at specified in clause 2.3.2 of this section. The test procedure shall be in accordance with IS 8263/IEC-60437.

- e) Mechanical Strength test: The test shall be carried out as per following procedure.

The complete insulator string alongwith its hardware fitting excluding arcing horn, corona control ring, grading ring, tension/suspension clamps shall be subjected to a load equal to 50% of the specified minimum ultimate tensile strength (UTS) which shall be increased at a steady rate to 67% of the minimum UTS specified. The load shall be held for five minutes and then removed. After removal of the load, the string components shall not show any visual deformation and it shall be possible to dismantle them by hand. Hand tools may be used to remove cotter pins and loosen the nuts initially. The string shall then be reassembled and loaded to 50% of UTS and the load shall be further increased at a steady rate till the specified minimum UTS and held for one minute. No fracture should occur during this period. The applied load shall then be increased until the failing load is reached and the value recorded.

- f) Salt-fog pollution withstand test as per IEC: 60507. The salinity level for composite long rod insulators shall be 160 Kg/m³ NaCl.

2.4.3.1.2 On Composite Polymer Insulator Units

- a) Tests on interfaces and connections of metal fittings as per IEC: 61109-2008.
- b) Assembled core load time test as per IEC: 61109-2008.
- c) Damage limit proof test and test of tightness of interface between end firings and insulator housing as per IEC: 61109-2008
- d) High Pressure washing test

SECTION - (SE) **SWITCHYARD ERECTION**

The washing of a complete insulator of each E&M rating is to be carried out at 3800 kPa with nozzles of 6 mm diameter at a distance of 3m from nozzles to the insulator, the washing shall be carried out for 10minutes. There shall be no damage to the sheath or metal fitting to housing interface. The verification shall be done by 1 minute wet power frequency withstand test at 680kV r.m.s for 400KV.

e) Brittle fracture resistance test

The test arrangement shall be according to Damage limit proof test with simultaneous application of 1N-HNO₃ acid directly in contact with naked FRP rod. The contact length of acid shall not be less than 40mm and thickness around the core not less than 10mm. The rod shall withstand 80% of SML for 96 hours.

f) Dye penetration test as per IEC: 61109-2008

g) Water diffusion test as per IEC: 61109-2008

h) Tracking and erosion test as per IEC: 61109-2008.

i) Hardness test as per IEC: 61109-2008.

j) Accelerated weathering test as per IEC: 61109-2008.

k) Flammability test as per IEC: 61109-2008.

l) Silicone content test

Minimum content of silicone shall be 30% and the same shall be verified through FT-IR spectroscopy & TGA analysis or any other approved/ acceptable method.

m) Recovery of Hydrophobicity test

1. The surface of selected samples shall be cleaned with isopropyl alcohol. Allow the surface to dry and spray with water. Record the HC classification. Dry the sample surface.
2. Treat the surface with corona discharges to destroy the hydrophobicity. This can be done utilizing a high frequency corona tester, Holding the electrode approximately 3mm from the sample surface, slowly move the electrode over an area approximately 1" x 1". Continue treating this area for 2 – 3 minutes, operating the tester at maximum output.
3. Immediately after the corona treatment, spray the surface with water and record the HC classification. The surface should be hydrophilic, with an HC value of 6 or 7. If not, dry the surface and repeat the corona treatment for a longer time until an HC of 6 or 7 is obtained. Dry the sample surface.
4. Allow the sample to recover and repeat the hydrophobicity measurement at several time intervals. Silicone rubber should recover to HC 1 – HC 2 within 24 to 48 hours, depending on the material and the intensity of the corona treatment.

n) Torsion test

SECTION - (SE)
SWITCHYARD ERECTION

Three complete insulators of each electrical and mechanical rating shall be subjected to a torsional load of 55Nm. The torsional strength test shall be made with test specimen adequately secured to the testing machine. The torsional load shall be applied to the test specimen through a torque member so constructed that the test specimen is not subjected to any cantilever stress. The insulator after torsion test must pass the Dye Penetration Test as per IEC 61109.

- o) Accelerated ageing test of 5000hrs as described in appendix-C of IEC 61109 or Test at multiple stresses of 5000 hrs as described in Annex-B of IEC - 62217

2.4.3.2 Acceptance Tests:

For Composite Long Rod Polymer Insulators

a.	Verification of dimensions	IEC : 61109-2008
b.	Galvanizing test	IEC : 60383
c.	Verification of end fittings	IEC : 61109-2008
d.	Recovery of Hydrophobicity	As per Cl. 2.4.3.1.2.m) above
e.	Verification of tightness of interface between end fittings and insulator housing and of specified mechanical load	IEC : 61109-2008
f.	Silicone content test	As per Cl. 2.4.3.1.2.l) above
g.	Brittle fracture resistance test	As per Cl. 2.4.3.1.2.e) above
h.	Dye penetration test	IEC : 61109-2008
i.	Water diffusion test	IEC : 61109-2008

In the event of failure of the sample to satisfy the acceptance test(s) specified in **2.4.3.2** above, the **re-test** procedure shall be as per IEC 61109.

2.4.3.3 Routine Tests

For Composite Long Rod Polymer Insulator Units

a)	Visual Examination	As per IEC:61109-2008
b)	Mechanical routine test	As per IEC:61109 -2008

2.4.4 Guaranteed Technical Particulars for Composite Long Rod Polymer Insulators

The technical parameters for composite long rod polymer insulator string shall be same of the insulator string specified in clause 2.3.2 of this section.

SECTION - (SE) **SWITCHYARD ERECTION**

3.0 AAC / ACSR CONDUCTOR

3.1 Details of AAC Conductor

- 3.1.1 The Conductor shall conform to IEC: 61089/IS: 398 (Part V) - 1992 except where otherwise specified herein.

The contractor shall supply the conductor as per the standard guaranteed technical particulars enclosed in Annexure-E of the technical specification, Section – Switchyard Erection and separate approval for **guaranteed technical particulars** is not required during detailed engineering.

3.2 Details of ACSR Conductor

- 3.2.1 The Conductor shall conform to IEC: 61089/IS: 398 (Part V) - 1992 except where otherwise specified herein.

- 3.2.2 The details of the ACSR Bersimis, ACSR Moose, ACSR Zebra and ACSR Panther conductors shall be as per the standard guaranteed technical particulars enclosed in Annexure-E of the technical specification, Section – Switchyard Erection and separate approval for **guaranteed technical particulars** is not required during detailed engineering.

3.3 Workmanship

- 3.3.1 The finished conductor shall be smooth, compact, uniform and free from all imperfections including kinks (**protrusion** of wires), wire cross over, over riding, looseness (wire being dislocated by finger/hand pressure and/or unusual bangle noise on tapping), material inclusions, white rust, powder formation or black spot (on account of reaction with trapped rain water etc.), dirt, grit etc.

- 3.3.2 All the Aluminium and steel strands shall be smooth, uniform and free from all imperfections, such as spills and splits, diemarks, scratches, abrasions, etc., after drawing.

- 3.3.3 The steel strands shall be hot dip galvanised and shall have a minimum zinc coating as indicated in the guaranteed technical particulars. The zinc coating shall be smooth, continuous and of uniform thickness, free from imperfections and shall withstand minimum three dips in standard Preece test. The steel wire rods shall be of such quality and purity that, when drawn to the size of the strands specified and coated with zinc, the finished strands and the individual wires shall be of uniform quality and have the same properties and characteristics as prescribed in IEC: 60888.

- 3.3.4 The steel strands shall be preformed and post formed in order to prevent spreading of strands in the event of cutting of composite core wire. Care shall be taken to avoid, damages to galvanisation during pre-forming and post-forming operation.

3.4 Joints in Wires

3.4.1 Aluminium Wires

- 3.4.1.1 During stranding, no aluminium wire welds shall be made for the purpose of achieving the required conductor length.

SECTION - (SE) **SWITCHYARD ERECTION**

3.4.1.2 No joints shall be permitted in the individual wires in the outer most layer of the finished conductor. However joints are permitted in the inner layer of the conductor unavoidably broken during stranding, provided such breaks are not associated with either inherently defective wire or with the use of short lengths of aluminium wires. Such joints shall not be more than four (4) per conductor length and shall not be closer than 15 meters from joint in the same wire or in any other aluminium wire of the completed conductor.

3.4.1.3 Joints shall be made by cold pressure butt welding and shall withstand a stress of not less than the breaking strength of individual strand guaranteed.

3.4.2 Steel Wires

There shall be no joint of any kind in the finished wire **used for the manufacturing** of the strand. There shall also be no strand joints or strand splices in any length of the completed stranded steel core of the conductor.

3.5 Tolerances

The manufacturing tolerances to the extent indicated in the guaranteed technical particulars shall be permitted in the diameter of individual aluminium and steel strands and lay-ratio of the conductor.

3.6 Materials

3.6.1 Aluminium

The aluminium strands shall be hard drawn from electrolytic aluminium rods having purity not less than 99.5% and a copper content not exceeding 0.04%. They shall have the same properties and characteristics as prescribed in IEC:60889.

3.6.2 Steel

The steel wire strands shall be drawn from high carbon steel wire rods produced by either the acid or the basic open-hearth process, the electric furnace process, or the basic oxygen process and shall conform to the chemical composition indicated in the guaranteed technical particulars.

The Steel wire strands shall have the same properties and characteristics as prescribed for regular strength steel wire in IEC: 60888.

3.6.3 Zinc

The zinc used for galvanising shall be electrolytic High Grade Zinc of 99.95% purity. It shall conform to and satisfy all the requirements of IS:209 -1979.

3.7 Standard Length

3.7.1 The conductor shall be supplied as required. No joint shall be allowed within a single span of stringing, jumpers and equipment interconnection.

3.8 Tests:

3.8.1 The following type, acceptance & routine tests and tests during manufacturing shall be carried out on the conductor.

SECTION - (SE)
SWITCHYARD ERECTION

3.8.1.1 Type Tests

In accordance with the stipulation of specification, the following type tests reports of the conductor shall be submitted for approval as per clause 9.2 of Section -GTR.

- | | | | |
|-----|--|---|-------------------|
| a) | UTS test on stranded conductor. |) | |
| | |) | |
| | |) | |
| b) | Corona extinction voltage test (dry) |) | As per Annexure-A |
| | |) | |
| | |) | |
| (c) | Radio Interference voltage test (dry) |) | |
| | |) | |
| | |) | |
| (d) | DC resistance test on stranded conductor |) | |
| | |) | |

3.8.1.2 Acceptance Tests

- | | | | |
|----|--|---|--------------------------|
| a) | Visual check for joints, scratches etc. and lengths of conductor |) | As per Annexure - A |
| | |) | |
| | |) | |
| b) | Dimensional check on steel and aluminium strands |) | |
| | |) | |
| | |) | |
| c) | Check for lay ratios of various layers |) | -do- |
| | |) | |
| | |) | |
| d) | Galvanising test on steel strands |) | |
| | |) | |
| | |) | |
| e) | Torsion and Elongation test on steel strands |) | |
| | |) | |
| | |) | |
| f) | Breaking load test on steel and aluminium strands |) | |
| | |) | |
| | |) | |
| g) | Wrap test on steel and aluminium strands |) | As per IEC:60888 & 60889 |
| | |) | |
| | |) | |
| h) | DC resistance test on aluminium strands |) | As per IEC:60889 |
| | |) | |
| | |) | |
| i) | UTS test on welded joint of aluminium strands |) | As per Annexure - A |
| | |) | |
| | |) | |

NOTE:

All the above tests except test mentioned at (a) shall be carried out on aluminium and steel strands after stranding only.

SECTION - (SE)
SWITCHYARD ERECTION

3.8.1.3 Routine Tests

- a) Check to ensure that the joints are as per specification.
- b) Check that there are no cuts, fins etc. on the strands.
- c) All acceptance tests as mentioned above to be carried out on each coil/drum (as applicable).

3.8.1.4 Tests During Manufacture

- a) Chemical analysis of zinc used for galvanising)
)
)
- b) Chemical analysis of aluminium used for making aluminium strands) As per Annexure - A
)
)
- c) Chemical analysis of steel used for making steel strands)
)
)

4.0 Galvanised Steel Earth wire

4.1 Details of Earth wire

4.1.1 The galvanised steel earth wire shall generally conform to the specification of ACSR core wire as mentioned in IEC:60888/IS: 398 (Part-II)-1976 except where otherwise specified herein.

The contractor shall supply the earthwire as per the standard guaranteed technical particulars enclosed in Annexure-E of the technical specification, Section – Switchyard Erection and separate approval **for guaranteed technical particulars** is not required during detailed engineering.

4.2 Workmanship

4.2.1 All steel strands shall be smooth, uniform and free from all imperfections, such as spills and splits, die marks, scratches, abrasions and kinks after drawing and also after stranding.

4.2.2 The finished material shall have minimum brittleness as it will be subjected to appreciable vibration while in use.

4.2.3 The steel strands shall be hot dip galvanized and shall have minimum Zinc coating after stranding, as stipulated in guaranteed technical particulars attached with. The zinc coating shall be smooth, continuous, of uniform thickness, free from imperfections. The steel wire rod shall be of such quality and purity that, when drawn to the size of the strands specified and coated with zinc, the finished strands shall be of uniform quality and have the same properties and characteristics as prescribed in ASTM designation B498-74.

4.2.4 The steel strands shall be preformed and post formed in order to prevent spreading of strands while cutting of composite earth wire. Care shall be taken to avoid damage to galvanisation during preforming and postforming operation.

4.2.5 To avoid susceptibility towards wet storage stains (white rust), the finished material shall be provided with a protective coating of boiled linseed oil.

SECTION - (SE)
SWITCHYARD ERECTION

4.3 Joints in Wires

There shall be no joints of any kind in the finished steel wire strand entering into the manufacture of the earth wire. There shall be no strand joints or strand splices in any length of the completed stranded earth wire.

4.4 Tolerances

The manufacturing tolerance to the extent of the limits as stipulated in guaranteed Technical Particulars attached with this specification shall only be permitted in the diameter of the individual steel strands and lay length of the earth wire.

4.5 Materials

4.5.1 Steel

The steel wire strands shall be drawn from high carbon steel rods and the chemical composition shall conform to the requirements as stipulated in Guaranteed Technical Particulars attached with.

4.5.2 Zinc

The zinc used for galvanising shall be electrolytic High Grade Zinc. It shall conform to and satisfy all the requirements of IS: 209 -1979.

4.6 Standard Length

4.6.1 The standard length of the earth wire shall be as stipulated in Guaranteed Technical Particulars attached with, with the specified tolerance on standard length.

4.8 TESTS

4.8.1 The following type, routine & acceptance tests and tests during manufacturing shall be carried out on the earthwire.

4.8.2 TYPE TESTS

In accordance with the stipulation of specification, the following type tests reports of the earthwire shall be submitted for approval as per clause 9.2 of Section - GTR.

- a) UTS test)
 - b) DC resistance test)
- As per Annexure - B

4.8.3 ACCEPTANCE TESTS

- a) Visual check for joints, scratches etc. and length of Earthwire)
 - b) Dimensional check)
 - c) Galvanising test)
 - d) Lay length check)
- As per Annexure - B

SECTION - (SE)
SWITCHYARD ERECTION

- e) Torsion test)
 - f) Elongation test)
 - g) Wrap test)
 - h) DC resistance test)
 - i) Breaking load test)
 - j) Chemical Analysis of steel)
- IS:398 (Part-III) - 1976

4.8.4 ROUTINE TESTS

- a) Check that there are no cuts, fins etc. on the strands.
- b) Check for correctness of stranding.

4.8.5 TESTS DURING MANUFACTURE

- a) Chemical analysis of zinc used for galvanising) As per Annexure - B
- b) Chemical analysis of steel)

5.0 ALUMINIUM TUBE

5.1 General

Aluminium used shall be grade 63401 WP (range 2) conforming to IS:5082.

The contractor shall supply the aluminium tubes as per the standard guaranteed technical particulars enclosed in Annexure-E of **this section** and separate approval for **guaranteed technical particulars** is not required during detailed engineering.

5.2 Constructional Features

5.2.1 For outer diameter (OD) & thickness of the tube there shall **not** be **any negative** tolerance, other requirements being as per IS: 2678 and IS: 2673.

5.2.2 The welding of aluminium tube shall be done by the qualified welders duly approved by the Employer.

5.3 Tests

In accordance with stipulations of the specification, Routine tests shall be conducted on tubular bus conductors as per IS:5082. Also the wall thickness and ovality of the tube shall be measured.

5.4 Technical Parameters

Sl. No.	Description	3" AL. TUBE	4" AL. TUBE	4.5" AL. TUBE	5" AL. TUBE
1.	Type	3" IPS	4" IPS	4.5" IPS	5" IPS

SECTION - (SE)
SWITCHYARD ERECTION

		(EH Type)	(EH Type)	(EH Type)	(H Type)
2.	Outer diameter	88.9 mm	114.2 mm	120.00 mm	141.30 mm
3.	Thickness	7.62 mm	8.51 mm	12.00 mm	9.53 mm
4.	Cross-sectional area of aluminium	1945.76 sq.mm	2825.61 sq.mm	4071.50 sq.mm	3945.11 sq.mm
5.	Weight	5.25 kg/m	7.7 kg/m	11.034 kg/m	10.652 kg/m

Sl. No.	Description	6" AL. TUBE	8" AL. TUBE	10" AL. TUBE
1.	Type	6" IPS (H Type)	8" IPS (H Type)	10" IPS (H Type)
2.	Outer diameter	150 mm	202 mm	252 mm
3.	Thickness	10 mm	16 mm	17 mm
4.	Cross-sectional area of aluminium	4398.2 Sq mm	9349.3 sq.mm	12550.6 sq.mm
5.	Weight	11.875 kg/m	25.243 kg/m	33.887 kg/m

6.0 **EARTHING CONDUCTORS**

6.1 **General**

All conductors buried in earth and concrete shall be of mild steel. All conductors above ground level and earthing leads shall be of galvanised steel, except for cable trench earthing. The minimum sizes of earthing conductor to be used are as indicated in clause 9.4 of this Section.

6.2 **Constructional Features**

6.2.1 **Galvanised Steel**

- a) Steel conductors above ground level shall be galvanised according to IS:2629.
- b) The minimum weight of the zinc coating shall be **610 gm/sq.m for normal area and 900 gm/sq.m for coastal area as specified in Section-Project** and minimum thickness shall be 85 microns.
- c) The galvanised surfaces shall consist of a continuous and uniformly thick coating of zinc, firmly adhering to the surfaces of steel. The finished surface shall be clean and smooth and shall be free from defects like discoloured patches, bare spots, unevenness of coating, spelter which is loosely attached to the steel globules, spiky deposits, blistered surfaces, flaking or peeling off etc. The presence of any of these defects noticed on visual or microscopic inspection shall render the material liable to rejection.

6.3 **Tests**

In accordance with stipulations of the specifications galvanised steel shall be subjected to four one minute dips in copper sulphate solution as per IS : 2633.

SECTION - (SE) **SWITCHYARD ERECTION**

7.0 SPACERS

7.1 General

Spacers shall conform to IS: 10162. The spacers are to be located at a suitable spacing to limit the short circuit forces as per IEC -60865. Wherever Employer's 765kV, 400 kV, 220kV & 132kV standard gantry structures are being used, the spacer span(s) for different conductor / span configurations and corresponding short circuit forces shall be as per Annexure-D. For strung buses, flexible type spacers shall be used whereas for jumpers and other connections rigid type spacers shall be used. All quad/twin conductors between equipments/ bus shall be provided with at least one spacer.

Wherever Employer's 765kV, 400 kV, 220kV & 132kV standard gantry structures are not being used, necessary spacer span calculation shall be provided by the contractor during detailed engineering for the approval of Employer.

7.2 Constructional Features

7.2.1 No magnetic material shall be used in the fabrication of spacers except for GI bolts and nuts.

7.2.2 Spacer design shall be made to take care of fixing and removing during installation and maintenance.

7.2.3 The design of the spacers shall be such that the conductor does not come in contact with any sharp edge.

7.3 Tests

Each type of spacers shall be subjected to the following type tests, acceptance tests and routine tests:

7.3.1 **Type Tests: Following type test reports shall be submitted for approval as per clause 9.2 of Section - GTR.**

a) **Clamp slip tests**

The sample shall be installed on test span of twin conductor bundle string or quadruple conductor bundle string (as applicable) at a tension of 44.2 kN. One of the clamps of the sample when subjected to a longitudinal pull of 2.5 kN parallel to the axis of the conductor shall not slip on the conductor. The permanent displacement between the conductor and the clamp of sample measured after removal of the load shall not exceed 1.0 mm. Similar tests shall be performed on the other clamps of the same sample.

b) Fault current test as per CI 5.14.2 of IS: 10162. Alternately, the same can be carried by simulated short circuit method for which compressive forces shall be based on IEC-60865.

c) Corona Extinction Voltage Test (Dry).

This test shall be performed on 765 kV, 400 kV and 220 kV spacers as per procedure mentioned at Annexure - C, Minimum Corona Extinction voltage shall be as per clause 2.3.2.

SECTION - (SE) **SWITCHYARD ERECTION**

d) RIV Test (Dry)

This test shall be performed as per procedure mentioned at Annexure - C, Maximum RIV levels shall be as per clause 2.3.2.

e) Resilience test (if applicable)

f) Tension Test

g) Log decrement test (if applicable)

h) Compression test

i) Galvanising test

7.3.2 Acceptance Test (As per IS:10162)

a) Visual examination

b) Dimensional verification

c) Movement test

d) Clamp slip test

e) Clamp bolt torque test (if applicable)

f) Assembly torque test

g) Compression test

h) Tension test

i) Galvanising test

j) Hardness test for neoprene (if applicable)

The shore hardness of different points on the elastometer surface of cushion grip clamp shall be measured by shore hardness meter. It shall be between 65 to 80.

k) Ultimate Tensile Strength Test

The UTS of the retaining rods shall be measured. It shall not be less than 35 kg/Sq. mm.

7.3.3 Routine test

a) Visual examination

b) Dimensional verification

8.0 BUS POST INSULATORS

The post insulators shall conform in general to latest IS: 2544, IEC-60168, IEC 60273 and IEC-60815.

SECTION - (SE) **SWITCHYARD ERECTION**

8.1 Constructional Features

- 8.1.1 Bus Post insulators shall consist of a porcelain part permanently secured in a metal base to be mounted on the supporting structures. They shall be capable of being mounted upright. They shall be designed to withstand any shocks to which they may be subjected to by the operation of the associated equipment. Only solid core insulators will be acceptable.
- 8.1.2 Porcelain used shall be homogeneous, free from lamination, cavities and other flaws or imperfections that might affect the mechanical or dielectric quality and shall be thoroughly vitrified, tough and impervious to moisture.
- 8.1.3 Glazing of the porcelain shall be of uniform brown in colour, free from blisters, burrs and other similar defects.
- 8.1.4 The insulator shall have alternate long and short sheds with aerodynamic profile, The shed profile shall also meet the requirements of IEC-60815 for the specified pollution level.
- 8.1.5 When operating at normal rated voltage there shall be no electric discharge between conductor and insulators which would cause corrosion or damage to conductors or insulators by the formation of substance produced by chemical action.
- 8.1.6 The design of the insulators shall be such that stresses due to expansion and contraction in any part of the insulator shall not lead to deterioration.
- 8.1.7 All ferrous parts shall be hot dip galvanised in accordance with the latest edition of IS: 2633, & IS: 2629. The zinc used for galvanising shall be grade Zn 99.95 as per IS: 209. The zinc coating shall be uniform, adherent, smooth, reasonably bright, continuous and free from imperfections such as flux ash, rust stains, bulky white deposits and blisters. The metal parts shall not produce any noise generating corona under the operating conditions.
- 8.1.8
- a) Every bolt shall be provided with a hot dip galvanised steel washer under the nut so that part of the threaded portion of the bolts is within the thickness of the parts bolted together.
 - b) Flat washer shall be circular of a diameter 2.5 times that of bolt and of suitable thickness. Where bolt heads/nuts bear upon the beveled surfaces they shall be provided with square tapered washers of suitable thickness to afford a seating square with the axis of the bolt.
 - c) All bolts and nuts shall be of steel with well formed hexagonal heads forged from the solid and shall be hot dip galvanised. The nuts shall be good fit on the bolts and two clear threads shall show through the nut when it has been finally tightened up.
- 8.1.9 Bidder shall furnish drawings for the essential design features of assembly of shells and metal parts, and number of shells per insulator.

8.2 Tests

In accordance with the stipulations of the specification, the post insulators shall be subjected to type, acceptance, sample and routine tests as per IEC-60168.

SECTION - (SE)
SWITCHYARD ERECTION

8.2.1 In accordance with the stipulation of specification, the following **type tests** reports of the post insulators shall be submitted for approval as per clause 9.2 of Section - GTR.

- a) Power frequency withstand test (dry & wet)
- b) Lightning impulse test (dry)
- c) Switching impulse test (wet) (For 420 kV and above class Insulator only)
- d) Measurement of R.I.V (Dry) (As per Annexure – C)
- e) Corona extinction voltage test (Dry) (As per Annexure – C)
- f) Test for deflection under load
- g) Test for mechanical strength.

8.2.2 In addition to acceptance/sample/routine tests as per IEC-60168, the following tests shall also be carried out.

- a) Soundness test, metallurgical tests and magnetic particle Inspection (**MPI**) test on MCI/SGI caps as acceptance test.
- b) All hot dip galvanised components shall be subjected to check for uniformity of thickness and weight of zinc coating on sample basis as an acceptance test.
- c) The bending test shall be carried out at 50% minimum cantilever strength load in four directions as a routine test and at 100% minimum cantilever strength load in four directions as an acceptance test.
- d) Acceptance norms for visual defects allowed at site and also at works shall be agreed in the Quality plan.

8.3 Technical Parameters of Bus Post Insulators.

Sl. No.	Description	800 kV	420 kV	245 kV	145 kV
a)	Type	Solid Core	Solid Core	Solid Core	Solid Core
b)	Voltage Class (kV)	800	420	245	145
c)	Dry and wet one minute power frequency withstand voltage (kV rms)	830	680	460	275
d)	Dry lightning impulse withstand Voltage (kVp)	±2100	±1425	±1050	±650
e)	Wet switching surge withstand voltage (kVp)	±1550	±1050	—	—
f)	Max. radio interference voltage (in microvolts) - Dry	1000 at 508 kV	500 at 305 kV	500 at 156 kV	500 at 105 kV
g)	Corona extinction voltage (kV rms) (min.)	508	320	156	105

SECTION - (SE)
SWITCHYARD ERECTION

h)	Cantilever Strength				
(i)	Total minimum cantilever strength (Kg)	800	800	800	600
i)	Minimum torsional moment	As per IEC-60273	As per IEC-60273	As per IEC-60273	As per IEC-60273
j)	Total height of insulator (mm)	5700	3650	2300	1500
k)	P.C.D Top (mm)	225	127	127	127
	Bottom (mm)	325	300	254	254
l)	No. of bolts				
	Top	4	4	4	4
	Bottom	8	8	8	8
m)	Diameter of bolt/holes (mm)				
	Top	M16	M16	M16	M16
	Bottom dia	18	18	18	18
n)	Pollution level as per IEC-60815	Heavy(III)	Heavy(III)	Heavy(III)	Heavy(III)
o)	Minimum total creepage distance for Heavy Pollution (mm)	20000	10500	6125	3165

8.3.1 If corona extinction voltage is to be achieved with the help of corona ring or any other similar device, the same shall be deemed to be included in the scope of the Contractor. Aluminium used for corona ring shall be of grade 63401 or 19501 conforming to IS:5082.

9.0 EARTHING

9.1 The earthing shall be done in accordance with requirements given hereunder and drawing titled 'Earthing Details' enclosed with the specification. The spacing for the main earthmat shall be provided by the Employer and the earthmat layout drawings shall be prepared by the contractor based on the spacing provided by the Employer. **The resistivity of the stone for spreading over the ground shall be considered as 3000 ohm-m under wet condition.** The resistivity measurement of stone (to be used for stone spreading) shall also be done by the Contractor to confirm the minimum resistivity value of stone considered in earth mat design. For measurement purpose, one sample of stones from each source (in case stones are supplied from more than one source) shall be used. The main earthmat shall be laid in the switchyard area in accordance with the approved earthmat layout.

9.2 Neutral points of systems of different voltages, metallic enclosures and frame works associated with all current carrying equipments and extraneous metal works associated with electric system shall be connected to a single earthing system unless stipulated otherwise.

9.3 Earthing and lightning protection system installation shall be in strict accordance with the latest editions of Indian Electricity Rules, relevant Indian Standards and Codes of practice and Regulations existing in the locality where the system is installed.

a) Code of practice for Earthing IS: 3043

SECTION - (SE)
SWITCHYARD ERECTION

- b) Code of practice for the protection of Building and allied structures against lightning IS: 2309.
- c) CEA Safety Regulations 2010 & Indian Electricity Act 2003 with latest amendments.
- d) National Electricity Safety code IEEE-80.

9.4 **Details of Earthing System**

Sl. No.	Item	Size	Material
a)	Main Earthing Conductor to be buried in ground	40mm dia	Mild Steel rod as per IS:2062/ SAE1018
b)	Conductor above ground & earthing leads (for equipment)	75x12mm G.S. flat	Galvanised Steel
c)	Conductor above ground & earthing leads (for columns & aux. structures)	75x12mm G.S. flat	Galvanised Steel
d)	Earthing of indoor LT panels, Control panels and outdoor marshalling boxes, Junction boxes & Lighting Panels etc.	50x6 mm G.S. flat	Galvanised Steel
e)	Rod Earth Electrode	40mm dia, 3000mm long	Mild Steel as per IS:2062/ SAE1018
f)	Pipe Earth Electrode (in treated earth pit) as per IS.	40mm dia, 3000mm long	Galvanised steel
g)	Earthing for motors	25x3mm GS flat	Galvanised steel
h)	Earthing conductor along outdoor cable trenches	50x6mm MS flat	Mild steel as per IS:2062/ SAE1018
l)	Earthing of Lighting Poles (for lighting poles outside switchyard)	40 mm dia 3000 mm long	Mild steel rod as per IS:2062/ SAE1018
j)	Isolator MOM Box	75X12 mm GS flat & Flexible copper braid	Galvanised steel and copper braid

The sizes of the earthing conductor indicated above are the minimum sizes.

9.5 **Earthing Conductor Layout**

- 9.5.1 Earthing conductors in outdoor areas shall be buried at least 600 mm below finished ground level unless stated otherwise.
- 9.5.2 Wherever earthing conductor crosses cable trenches, underground service ducts, pipes, tunnels, railway tracks etc., it shall be laid minimum 300 mm below them and shall be circumvented in case it fouls with equipment/structure foundations.
- 9.5.3 Tap-connections from the earthing grid to the equipment/structure to be earthed shall be terminated on the earthing terminals of the equipment/structure as per "Standard Earthing Details – Drg No. **C/ENG/STD/EARTHINGS/09**" enclosed.

SECTION - (SE) **SWITCHYARD ERECTION**

- 9.5.4 Earthing conductors or leads along their run on cable trench, ladder, walls etc. shall be supported by suitable welding/cleating at intervals of 750 mm. Wherever it passes through walls, floors etc., PVC sleeves shall be provided for the passage of the conductor and both ends of the sleeve shall be sealed to prevent the passage of water through the sleeves.
- 9.5.5 Earthing conductor around the building shall be buried in earth at a minimum distance of 1500 mm from the outer boundary of the building.
- 9.5.6 Earthing conductors crossing the road shall be laid 300mm below road or at greater depth to suit the site conditions.
- 9.5.7 Earthing conductors embedded in the concrete shall have approximately 50mm concrete cover.

9.6 ELECTRO-MAGNETIC FIELD CONTROL

The contractor shall provide galvanised steel earth wire at 8m level in the area where three interconnection levels (equipment interconnection, bus & jack bus interconnection) are present at 765kV switchyard to limit electric and magnetic field within permissible limit.

9.7 Equipment and Structure Earthing

- 9.7.1 Earthing pads shall be provided for the apparatus/equipment at accessible position. The connection between earthing pads and the earthing grid shall be made by two short earthing leads (one direct and another through the support structure) free from kinks and splices. In case earthing pads are not provided on the item to be earthed, same shall be provided in consultation with Employer.
- 9.7.2 Whether specifically shown in drawings or not, steel/RCC columns, metallic stairs etc. shall be connected to the nearby earthing grid conductor by two earthing leads. Electrical continuity shall be ensured by bonding different sections of hand-rails and metallic stairs.
- 9.7.3 Metallic pipes, conduits and cable tray sections for cable installation shall be bonded to ensure electrical continuity and connected to earthing conductors at regular interval. Apart from intermediate connections, beginning points shall also be connected to earthing system.
- 9.7.4 Metallic conduits shall not be used as earth continuity conductor.
- 9.7.5 Wherever earthing conductor crosses or runs along metallic structures such as gas, water, steam conduits, etc. and steel reinforcement in concrete it shall be bonded to the same.
- 9.7.6 Light poles, junction boxes on the poles, cable and cable boxes/glands, lockout switches etc. shall be connected to the earthing conductor running alongwith the supply cable which in turn shall be connected to earthing grid conductor at a minimum two points whether specifically shown or not.
- 9.7.7 Railway tracks within switchyard area shall be earthed at a spacing of 30m and also at both ends.
- 9.7.8 Earthing conductor shall be buried 2000 mm outside the switchyard fence. All the gates and every alternate post of the fence shall be connected to earthing grid.

SECTION - (SE) **SWITCHYARD ERECTION**

The stone spreading shall also be done 2000 mm outside switchyard fence. The criterion for stone spreading shall be followed in line with requirement specified elsewhere in the specification

- 9.7.9 Flexible earthing connectors shall be provided for the moving parts.
- 9.7.10 All lighting panels, junction boxes, receptacles fixtures, conduits etc. shall be grounded in compliance with the provision of I.E. rules
- 9.7.11 A continuous ground conductor of 16 SWG GI wire shall be run all along each conduit run. The conductor shall be connected to each panel ground bus. All junction boxes, receptacles, switches, lighting fixtures etc. shall be connected to this 16 SWG ground conductor.
- 9.7.12 50mm x 6mm MS flat shall run on the top tier and all along the cable trenches and the same shall be welded to each of the racks. Further this flat shall be earthed at both ends and at an interval of 30 mtrs. The M.S. flat shall be finally painted with two coats of Red oxide primer and two coats of Zinc riched enamel paint.
- 9.7.13 One number 40 mm dia, 3000 mm long MS earth electrode with test link, CI frame and cover shall be provided to connect each down conductor of surge arresters, capacitive voltage transformers, lightning masts and towers with peak.

9.8 Jointing

- 9.8.1 Earthing connections with equipment earthing pads shall be bolted type. Contact surfaces shall be free from scale, paint, enamel, grease, rust or dirt. Two bolts shall be provided for making each connection. Equipment bolted connections, after being checked and tested, shall be painted with anti corrosive paint/compound.
- 9.8.2 Connection between equipment earthing lead and main earthing conductors and between main earthing conductors shall be welded type. For rust protections, the welds should be treated with red oxide primer and afterwards coated with two layers bitumen compound to prevent corrosion.
- 9.8.3 Steel to copper connections shall be brazed type and shall be treated to prevent moisture ingress.
- 9.8.4 Resistance of the joint shall not be more than the resistance of the equivalent length of the conductor.
- 9.8.5 All ground connections shall be made by electric arc welding. All welded joints shall be allowed to cool down gradually to atmospheric temperature before putting any load on it. Artificial cooling shall not be allowed.
- 9.8.6 All arc welding with large dia. conductors shall be done with low hydrogen content electrodes.
- 9.8.7 The 75x12mm GS flat shall be clamped with the equipment support structures at 1000mm interval.

SECTION - (SE) **SWITCHYARD ERECTION**

9.9 Power Cable Earthing

Metallic sheaths and armour of all multi core power cables shall be earthed at both equipment and switchgear end. Sheath and armour of single core power cables shall be earthed at switchgear end only.

9.10 Specific Requirement for Earthing Systems

9.10.1 Each earthing lead from the neutral of the power transformer/Reactor shall be directly connected to two numbers pipe electrodes in treated earth pit (as per IS) which in turn, shall be buried in Cement Concrete pit with a ISI marked cast iron cover hinged to a cast iron frame to have an access to the joints. All accessories associated with transformer/reactor like cooling banks, radiators etc. shall be connected to the earthing grid at minimum two points.

9.10.2 Earthing terminal of each lightning arrester & capacitor voltage transformer shall be directly connected to rod earth electrode which in turn, shall be connected to station earthing grid.

9.10.3 Auxiliary earthing mat comprising of 40mm dia M.S. rods closely spaced (300 mm x 300 mm) conductors shall be provided at depth of 300mm from ground level below the operating handles of the M.O.M. Box of the isolators. M.O.M. boxes shall be directly connected to the auxiliary earthing mat. Flexible copper braid connection to be provided between MOM box and GI flat to take care of soil sagging. The size of auxiliary earthing mat shall be of 1500mmx1500mm size for 220kV and above voltage class isolators and 900mmx900mm size for 132kV and below voltage class isolators. Factory welded auxiliary earthmat is preferable.

9.11 Insulating mats

9.11.1 The scope covers supply and laying of insulating mats of "class A" conforming to IS: 15652-2006.

9.11.2 These insulating mats shall be laid in front of all floor mounted AC and DC switchboards and control & relay panels located in control room building/ Switchyard panel room.

9.11.3 The insulating mats shall be made of elastomer material free from any insertions leading to deterioration of insulating properties. It shall be resistant to acid, oil and low temperature.

9.11.4 Upper surface of the insulating mats shall have small aberration (rough surface without edges) to avoid slippery effects while the lower surface shall be plain or could be finished slip resistant without affecting adversely the dielectric property of the mat.

9.11.5 Insulating mat (**wherever applicable**) shall be of pastable type, to be fixed permanently on the front of the panels except for the chequered plate area which shall not be pasted as per requirement. The insulating mats shall generally be fixed and joints shall be welded as per recommendations in Annexure-A of IS: 15652.

9.11.6 Width of insulating mats shall generally be of 1.5 meters or as per site requirements. Length shall be supplied as per site requirements.

9.11.7 The insulating mats offered shall conform to IS: 15652-2006.

SECTION - (SE) **SWITCHYARD ERECTION**

10.0 Bus Bars

The brief description of the bus switching scheme, bus bar layout and equipment connection to be adopted are indicated elsewhere in the specification. The bus bar arrangements are shown in electrical layout drawings enclosed with the bid documents.

10.1 The Contractor shall furnish supporting calculations where the design is to be done by the contractor for the bus bars/conductors to show adequacy of design parameters for:

- a) Fibre-stress (applicable for aluminum tube)
- b) Cantilever strength of post insulators (applicable for aluminum tube)
- c) Aeolian vibrations (applicable for aluminum tube)
- d) Vertical deflection of bus bars (applicable for aluminum tube)
- e) Short circuit forces in bundle conductor and spacer location for each span of ACSR conductor stringing as per layout drawings.

10.1.1 The welds in the aluminium tubes shall be kept to the minimum and there shall not be more than one weld per span. The procedure and details of welding shall be subject to Employer's approval. Material for welding sleeve shall be same as that of Aluminium tube. Welding sleeve shall be of 600mm length

10.1.2 Corona bells shall be provided wherever the bus extends beyond the clamps and on free ends, for sealing the ends of the tubular conductor against rain and moisture and to reduce the electrostatic discharge loss at the end points. There shall be a small drain hole in the corona bell. The material of Corona bell shall be Aluminium alloy similar to that of clamps & connectors.

10.1.3 To minimise the vibrations in the aluminium tubes, damping conductor shall be provided inside the aluminium tubes. For this purpose, the cut pieces of ACSR conductor which otherwise are considered wastages, shall be used as damping conductor.

10.1.4 Details of past experience of the persons proposed to be employed for Aluminium tube welding and the test reports of the welded pieces to prove the electrical and mechanical characteristics shall also be furnished **to Employer**. Welding at site shall be done by adopting a qualified procedure and employing qualified welders as per ASME-Section IX.

10.1.5 Joints shall be avoided in strung bus to avoid joint failure / hot spots and hardwares to be designed accordingly.

11.0 BAY EQUIPMENT

11.1 The disposition of various bay equipments shall be as per single line diagrams and layout drawings.

11.2 Bay Marshalling Kiosk:-

Bay marshalling kiosk shall be fabricated from 304 grade stainless steel of minimum thickness of 1.6mm. For other constructional details, technical specification of section-GTR shall be referred. Further, for stainless steel type bay marshaling kiosk, no painting is envisaged.

SECTION - (SE) **SWITCHYARD ERECTION**

One no. of bay marshalling kiosk shall be provided for each 765 kV, 400 kV, 220 kV and 132 kV bay under present scope. For one and half breaker scheme, one number bay marshalling kiosk shall be provided for each controlling feeder (Line/ transformer/ bus reactor etc) of the diameter and no bay marshalling kiosks are required to be provided for the tie bays. In addition to the requirements specified elsewhere in the specification, the bay marshalling kiosk shall have two distinct compartments for the following purpose:-

A. For 765kV , 400 kV & 220 kV Bays

- (i) To receive two incoming 415V, 3 phase, 63Amps, AC supply with auto changeover and MCB unit and distribute minimum nine (9) numbers outgoing 415V, 3 phase, 16 Amps AC supplies controlled by MCB.
- (ii) To distribute minimum two numbers outgoing 415V, 63Amps three phase supplies to be controlled by MCB to be drawn from above 3 phase incomers for supply to switchyard panel rooms.
- (iii) To distribute minimum ten numbers outgoing 240V, 10 Amps single phase supplies to be controlled by MCB to be drawn from above 3 phase incomers.
- (iv) Necessary Terminal Blocks for terminating cables from ACDB and necessary heating circuits.

B. For 132kV & 66 kV Bays

- (i) To receive two incoming 415V, 3 phase, 63Amps, AC supply with auto changeover and MCB unit and distribute minimum four (4) number outgoing 415V, 3 phase, 16 Amps AC supplies controlled by MCB.
- (ii) To distribute minimum six (6) numbers outgoing 240V, 10 Amps single phase supplies to be controlled by MCB to be drawn from above 3 phase incomers.
- (iii) 100 nos. terminal blocks in vertical formation for interlocking facilities for substations without automation system.
- (iv) Necessary Terminal Blocks for terminating cables from ACDB and necessary heating circuits.

11.3 Further, all Bay Marshalling Kiosks shall be erected such that a minimum height of 1000mm is maintained between FGL & bottom of the marshalling box. Size of Marshalling box shall be such that cables are properly terminated and wires are dressed with provision of loop.

11.4 **BAY AND PHASE IDENTIFICATION**

11.4.1 The name plate for the bays shall be provided by the contractor as per standard drawing (Drawing no. C/ENG/STD/BAY NAME PLATE) enclosed in this technical specification.

11.4.2 All the phases are to be identified by painting the structures Red, Yellow and Blue by reflecting colour as per as built condition. Phase identification colour is to be provided around the top of the structure with colour band of 100 mm width at a height of approximately 2000mm from the finished ground level.

SECTION - (SE) **SWITCHYARD ERECTION**

12.0 LIGHTNING PROTECTION

- 12.1 Direct stroke lightning protection (DSLPP) shall be provided in the EHV switchyard by lightning masts and shield wires. The layout drawings enclosed indicate the tentative arrangement. The final arrangement shall be decided after approval of the DSLPP calculations.
- 12.2 The lightning protection system shall not be in direct contact with underground metallic service ducts and cables.
- 12.3 Conductors of the lightning protection system shall not be connected with the conductors of the safety earthing system above ground level.
- 12.4 Down conductors shall be cleated on the structures at 2000 mm interval.
- 12.5 Connection between each down conductor and rod electrodes shall be made via test joint (pad type compression clamp) located approximately 1500 mm above ground level. The rod electrode shall be further joined with the main earthmat.
- 12.6 Lightning conductors shall not pass through or run inside G.I. conduits.
- 12.7 Lightning protection shall also be provided for various buildings like control building, FFPH, Township buildings as per relevant standard.

13.0 EQUIPMENT ERECTION DETAILS

- 13.1 All circuit breaker and isolator erection shall be done under the supervision of equipment manufacturer and erection of all switchyard equipments shall be done as per POWERGRID approved Field Quality Plan (FQP) and as per provision of Technical Specification.
- 13.2 For equipment interconnection, the surfaces of equipment terminal pads, Aluminium tube, conductor & terminal clamps and connectors shall be properly cleaned. After cleaning, contact grease shall be applied on the contact surfaces of equipment terminal pad, Aluminium tube/conductor and terminal clamps to avoid any air gap in between. Subsequently bolts of the terminal pad/terminal connectors shall be tightened and the surfaces shall be cleaned properly after equipment interconnection.
- 13.3 Muslin or leather cloth shall be used for cleaning the inside and outside of hollow insulators.
- 13.4 All support insulators, circuit breaker interrupters and other fragile equipment shall preferably be handled with cranes having suitable booms and handling capacity.
- 13.5 Bending of Aluminium tube and compressed air piping if any should be done by a bending machine and through cold bending only. Bending shall be such that inner diameter of pipe is not reduced.
- All welding done at site for equipment and structures, shall be painted with zinc rich paint immediately to avoid corrosion.
- 13.6 Cutting of the pipes wherever required shall be such as to avoid flaring of the ends. Hence only a proper pipe cutting tool shall be used. Hack saw shall not be used.
- 13.7 Handling of equipment shall be done strictly as per manufacturer's/supplier's

SECTION - (SE) **SWITCHYARD ERECTION**

instructions/instruction manual.

13.8 Handling equipment, sling ropes etc. should be tested periodically before erection for strength.

13.9 The slings shall be of sufficient length to avoid any damage to insulator due to excessive swing, scratching by sling ropes etc.

14.0 **STORAGE**

14.1 The Contractor shall provide and construct adequate storage shed as per the Filed Quality Plan for proper storage of equipments, where sensitive equipments shall be stored indoors. All equipments during storage shall be protected against damage due to acts of nature or accidents. The storage instructions of the equipment manufacturer/Employer shall be strictly adhered to. POWERGRID approved Field Quality Plan shall be followed alongwith the provision of Technical Specification for storage.

15.0 **CABLING MATERIAL**

15.1 **CABLE TAGS AND MARKERS**

15.1.1 Each cable and conduit run shall be tagged with numbers that appear in the cable and conduit schedule.

15.1.2 The tag shall be of aluminium with the number punched on it and securely attached to the cable conduit by not less than two turns of 20 SWG GI wire conforming to IS:280. Cable tags shall be of rectangular shape for power cables and of circular shape for control cables.

15.1.3 Location of cables laid directly underground shall be clearly indicated with cable route marker made of galvanised iron plate.

15.1.4 Location of underground cable joints shall be indicated with cable **route** marker with an additional inscription "Cable joints".

15.1.5 The **cable route** marker shall project 150 mm above ground and shall be spaced at an interval of 30 meters and at every change in direction. They shall be located on both sides of road and drain crossings as per relevant standard.

15.1.6 Cable tags shall be provided on all cables at each end (just before entering the equipment enclosure), on both sides of a wall or floor crossing, on each duct/conduit entry and at each end & turning point in cable tray/trench runs. Cable tags shall be provided inside the switchgear, motor control centres, control and relay panels etc., wherever required for cable identification, where a number of cables enter together through a gland plate.

15.2 **Cable Supports and Cable Tray Mounting Arrangements**

15.2.1 The Contractor shall provide embedded steel inserts on concrete floors/walls to secure supports by welding to these inserts or available building steel structures.

15.2.2 The supports shall be fabricated from standard structural steel members.

15.2.3 Insert plates will be provided at an interval of 750 mm wherever cables are to be supported without the use of cable trays, such as in trenches, while at all other

SECTION - (SE) **SWITCHYARD ERECTION**

places these will be at an interval of 2000 mm.

15.2.4 Vertical run of cables on equipment support structure shall be supported on perforated cable trays of suitable width which shall be suitably bolted/clamped with the equipment support structure.

15.3 Cable Termination and Connections

15.3.1 The termination and connection of cables shall be done strictly in accordance with cable and termination kit manufacturer's instructions, drawing and/or as directed by the Employer.

15.3.2 The work shall include all clamping, fittings, fixing, plumbing, soldering, drilling, cutting, taping, heat shrinking (where applicable), connecting to cable terminal, shorting and grounding as required to complete the job.

15.3.3 Supply of all consumable material shall be in the scope of Contractor.

15.3.4 The equipment will be generally provided with undrilled gland plates for cables/conduit entry. The Contractor shall be responsible for drilling of gland plates, painting and touching up. Holes shall not be made by gas cutting.

15.3.5 Control cable inside control panel/switchgear/MCCB/MCC/ miscellaneous panels shall be neatly bunched, clamped and tied with nylon strap or PVC perforated strap to keep them in position.

15.3.6 The Contractor shall use printed ferrules for control cable cores at all terminations, as instructed by the Employer. Each cable wire shall be identified with a number and detailed cable schedule may be prepared indicating the wire numbers.

15.3.7 Spare cores shall be similarly encased & tagged with cable numbers and coiled up with end cap.

15.3.8 All cable entry points shall be sealed and made vermin and dust proof. Unused openings shall be effectively closed.

15.3.9 Double compression type nickel plated (coating thickness not less than 10 microns) brass cable glands shall be provided by the Contractor for all power and control cables to provide dust and weather proof terminations.

15.3.10 The cable glands shall conform to BIS:6121. They shall comprise of heavy duty brass casting, machine finished and nickel plated, to avoid corrosion and oxidation. Rubber components used in cable glands shall be neoprene and of tested quality. Cable glands shall be of approved make.

15.3.11 The cable glands shall also be suitable for dust proof and weather proof termination.

15.3.12 If the cable-end box or terminal enclosure provided on the equipment is found unsuitable and requires modification, the same shall be carried out by the Contractor, as directed by the Employer.

15.3.13 Crimping tool used shall be of approved design and make.

15.3.14 Control Cable lugs shall be tinned copper solderless crimping type conforming to

SECTION - (SE) **SWITCHYARD ERECTION**

IS-8309 & 8394. Aluminium Bimetallic lugs for power cables as required shall be used depending upon type of cables and terminations.

15.3.15 Solderless crimping of terminals shall be done by using corrosion inhibitory compound. The cable lugs shall suit the type of terminals provided.

15. 4 Storage and handling of Cable Drums

15.4.1 Cable drums shall be unloaded, handled and stored in an approved manner and rolling of drums shall be avoided as far as possible. For short distances, the drums may be rolled provided they are rolled slowly and in proper direction as marked on the drum.

16.0 DIRECTLY BURIED CABLES

16.1 The Contractor shall construct the cable trenches required for directly buried cables. The scope of work shall include excavation, preparation of sand bedding, soil cover, supply and installation of brick or concrete protective covers, back filling and ramming, supply and installation of route markers and joint markers.

16.2 The cable (power and control) between LT station, DG set location and fire lighting pump house and control room shall be laid in the buried cable trenches. In addition to the above, for lighting purpose also, buried cable trench can be used in outdoor area.

16.3 Power cables from Main Switchboard to colony shall be laid in buried cable trench. Location of cable termination point at colony shall be as per site condition and shall be decided in consultation with Employer's site-in-charge. Power Cables for oil filtration plant shall be laid in open cable trench or buried trench upto transformer/reactor area and can be looped from adjacent receptacles provided for power supply of oil filtration plant.

16.4 Cable route and joint markers and RCC warning covers shall be provided wherever required. The voltage grade of cables shall be engraved on the marker. Cable markers shall be grounded in a concrete base.

17.0 INSTALLATION OF CABLES

17.1 Cabling in the control room shall be done on ladder type cable trays for vertical runs while cabling in switchyard area shall be done on angles in the trench.

17.2 All cables from bay cable trench to equipments including and all interpole cables (both power and control) for all equipment, shall be laid in PVC pipes of minimum 50 mm nominal outside diameter of class 4 as per IS 4985 which shall be buried in the ground at a depth of 250mm below finish formation level. Separate PVC pipes shall be laid for control and power cables. Cable pull boxes of adequate size shall be provided if required. **For vertical runs on equipments, perforated cable trays shall be provided for all equipments under scope of the contract or any equipment to be provided by the owner (including for owner supplied circuit breakers).**

17.3 Cables shall be generally located adjoining the electrical equipment through the pipe insert embedded in the floor. In the case of equipments located away from cable trench either pipe inserts shall be embedded in the floor connecting the cable trench and the equipment or in case the distance is small, notch/opening on the wall shall be provided. In all these cases necessary bending radius as

SECTION - (SE) **SWITCHYARD ERECTION**

recommended by the cable manufacturer shall be maintained. Embedded pipes shall be dressed properly at the equipment termination points.

- 17.4 Cable racks and supports shall be painted after installation with two coats of metal primer (comprising of red oxide and zinc chromate in a synthetic medium) followed by two finishing coats of aluminium paint. The red oxide and zinc chromate shall conform to IS:2074.
- 17.5 Suitable arrangement should be used between fixed pipe/cable trays and equipment terminal boxes, where vibration is anticipated.
- 17.6 Power and control cables in the cable trench shall be laid in separate tiers. The order of laying of various cables shall be as follows, for cables other than directly buried.
- a) Power cables preferably on top tiers.
 - b) Control instrumentation and other service cables in bottom tiers.
 - c) For cabling from control room to switchyard in main cable trench, cable shall be laid such that bottom tiers are preferably filled first and top tiers are kept for filling future cables as per the instructions of Engineer-In-Charge.
- 17.7 For Single core cables in trefoil formation shall be laid with a distance of three times the diameter of cable between trefoil centre lines. Further, for horizontal cables a minimum centre to centre distance equal to twice the diameter of the cable of higher size of cables shall be maintained.
- 17.8 Trefoil clamps for single core cables shall be of pressure die cast aluminium (LM-6), Nylon-6 or fibre glass and shall include necessary fixing GI nuts, bolts, washer etc. These are required at every 2 metre of cable runs.
- 17.9 Power and control cables shall be securely fixed to the trays/supports with self locking type nylon ties with de-interlocking facility at every 5 metre interval for horizontal run. Vertical and inclined cable runs shall be secured with 25 mm wide and 2 mm thick aluminium strip clamps at every 2m.
- 17.10 Cables shall not be bent below the minimum permissible limit. The permissible limits are as follows:
- | Table of Cable and | Minimum bending radius |
|--------------------|------------------------|
| Power cable | 12 D |
| Control cable | 10 D |
- D is overall diameter of cable
- 17.11 Where cables cross roads, drains and rail tracks, these shall be laid in reinforced spun concrete or steel pipes buried at not less than one metre depth. The size of hume/steel pipe shall be such that approximately 70% area is only occupied. For meeting future requirement, additional hume/steel pipe shall be laid for future bay provision.
- 17.12 In each cable run some extra length shall be kept at a suitable point to enable one (for LT cables)/ two (for H.T. cables) straight through joints to be made in case the cable develop fault at a later date.
- 17.13 Selection of cable drums for each run shall be so planned as to avoid using straight through joints. Cable splices will not be permitted except where called for

SECTION - (SE) **SWITCHYARD ERECTION**

by the drawings, unavoidable or where permitted by the Employer. If straight through joints are unavoidable, the Contractor shall use the straight through joints kit of reputed make.

- 17.14 Control cable terminations inside equipment enclosures shall have sufficient lengths so that changing of termination in terminal blocks can be done without requiring any splicing.
- 17.15 Metal screen and armour of the cable shall be bonded to the earthing system of the station, wherever required by the Employer.
- 17.16 Rollers shall be used at intervals of about two metres while pulling cables to avoid damage.
- 17.17 All due care shall be taken during unreeling, laying and termination of cable to avoid damage due to twist, kinks, sharp bends, etc.
- 17.18 Cable ends shall be kept sealed to prevent damage. In cable vault, fire resistant seal shall be provided underneath the panels.
- 17.19 Inspection on receipt, unloading and handling of cables shall generally be in accordance with IS:1255 and other Indian Standard Codes of practices.
- 17.20 Wherever cable pass through floor or through wall openings or other partitions, GI/PVC wall sleeves with bushes having a smooth curved internal surface so as not to damage the cable, shall be supplied, installed and properly sealed by the Contractor at no extra charges.
- 17.21 In case the outer sheath of a cable is damaged during handling/installation, the Contractor shall repair it at his own cost to the satisfaction of the Employer. In case any other part of a cable is damaged, the same shall be replaced by a healthy cable at no extra cost to the Employer, i.e. the Contractor shall not be paid for installation and removal of the damaged cable.
- 17.22 All cable terminations shall be appropriately tightened to ensure secure and reliable connections. The Contractor shall cover the exposed part of all cable lugs whether supplied by him or not with insulating tape, sleeve or paint.
- 17.23 **Cable trays**
- i) The cable trays shall be of G.S Sheet and minimum thickness of sheet shall be 2mm.
 - ii) The Contractor shall perform all tests and inspection to ensure that material and workmanship are according to the relevant standards. Contractor shall have to demonstrate all tests as per specification and equipment shall comply with all requirements of the specification.
 - a) Test for galvanising (Acceptance Test)
The test shall be done as per approved standards.
- 17.24 **Conduits, Pipes and Duct Installation**
- 17.24.1 Contractor shall supply and install all rigid conduits, mild steel pipes, flexible conduits, hume pipes etc. including all necessary sundry materials such as tees, elbows, check nuts, bushing, reducers, enlargers, coupling cap, nipples, gland

SECTION - (SE) **SWITCHYARD ERECTION**

sealing fittings, pull boxes etc as required. The size of the conduit/pipe shall be selected on the basis of 40% fill criterion.

- 17.24.2 Contractor shall have his own facility for bending, cutting and threading the conduits at site. Cold bending should be used. All cuts & threaded ends shall be made smooth without leaving any sharp edges. Anticorrosive paint shall be applied at all field threaded portions.
- 17.24.3 All conduit/pipes shall be extended on both sides of wall/floor openings. The fabrication and installation of supports and the clamping shall be included in the scope of work by Contractor.
- 17.24.4 Installation of optical cables/ special cables:**
- GI pipe (light grade) of suitable size (minimum 25 mm) along with required bends, joints etc. shall be used for special cables such as cables for visual monitoring system (VMS), substation automation system (SAS). Further, single pipe can be used for laying multiple cables.**
- 17.24.5 All conduits/pipes shall have their ends closed by caps until cables are pulled. After cables are pulled, the ends of conduits/pipes shall be sealed in an approved manner to prevent damage to threaded portions and entrance of moisture and foreign material.
- 17.24.6 All unarmoured cables shall run within the conduits from lighting panels to lighting fixtures, receptacles etc.
- 17.24.7 Size of conduit for lighting shall be selected by the Contractor during detailed engineering.
- 17.24.8 Exposed conduits shall be run in straight lines parallel to building columns, beams and walls. Unnecessary bends and crossings shall be avoided to present a neat appearance.
- 17.24.9 Conduit supports shall be provided at an interval of 750mm for horizontal runs and 1000mm for vertical runs.
- 17.24.10 Conduit supports shall be clamped on the approved type spacer plates or brackets by saddles or U- bolts. The spacer plates or brackets in turn, shall be securely fixed to the building steel by welding and to concrete or brick work by grouting or by nylon rawl plugs. Wooden plug inserted in the masonry or concrete for conduit support is not acceptable.
- 17.24.11 Embedded conduits shall be securely fixed in position to preclude any movement. In fixing embedded conduit, if welding or brazing is used, extreme care should be taken to avoid any injury to the inner surface of the conduit.
- 17.24.12 Spacing of embedded conduits shall be such as to permit flow of concrete between them.
- 17.24.13 Where conduits are placed alongwith cable trays, they shall be clamped to supporting steel at an interval of 600mm.
- 17.24.14 For directly embedding in soil, the conduits shall be coated with an asphalt-base compound. Concrete pier or anchor shall be provided wherever necessary to support the conduit rigidly and to hold it in place.

SECTION - (SE) **SWITCHYARD ERECTION**

- 17.24.15 Conduit shall be installed in such a way as to ensure against trouble from trapped condensation.
- 17.24.16 Conduits shall be kept, wherever possible, at least 300mm away from hot pipes, heating devices etc. when it is evident that such proximity may reduce the service life of cables.
- 17.24.17 Slip joints shall be provided when conduits cross structural expansion joints or where long run of exposed conduits are installed, so that temperature change will cause no distortion due to expansion or contraction of conduit run.
- 17.24.18 For long conduit run, pull boxes shall be provided at suitable intervals to facilitate wiring.
- 17.24.19 Conduit shall be securely fastened to junction boxes or cabinets, each with a lock nut inside and outside the box.
- 17.24.20 Conduits joints and connections shall be made thoroughly water-tight and rust proof by application of a thread compound which insulates the joints. White lead is suitable for application on embedded conduit and red lead for exposed conduit.
- 17.24.21 Field bends shall have a minimum radius of four (4) times the conduit diameter. All bends shall be free of kinks, indentations or flattened surfaces. Heat shall not be applied in making any conduit bend. Separate bends may be used for this purpose.
- 17.24.22 The entire metallic conduit system, whether embedded or exposed, shall be electrically continuous and thoroughly grounded. Where slip joints are used, suitable bonding shall be provided around the joint to ensure a continuous ground circuit.
- 17.24.23 After installation, the conduits shall be thoroughly cleaned by compressed air before pulling in the wire.
- 17.24.24 Lighting fixtures shall not be suspended directly from the junction box in the main conduit run.

17.25 Cable Sealing System

Modular multi-diameter cable sealing system consisting of frames, blocks and accessories shall be installed where the underground and over ground cables enter or leave concrete bay kiosks/switchyard panel room & control rooms in the substations. Cable sealing system shall consist of multi-diameter type peel-able or adjustable blocks of different sizes to suit the various cables. It should be simple, easy and quick to assemble & re-assemble the cable sealing system. Solid blocks shall not be used on frame. Frames & stay-plate material shall be of galvanized steel and for compression, single piece wedge with galvanized steel bolts shall be used. 30% spare blocks on the frame shall be provided for expansion in future. Cable sealing system should have been tested for fire/water/smoke tightness.

Cable sealing system having earthing strip can alternately be used in place of cable gland arrangement for indoor panels such as LCC, C&R, PLCC panels etc.

SECTION - (SE) **SWITCHYARD ERECTION**

18.0 LIGHTING JUNCTION BOX

The Contractor shall supply and install ISI marked junction boxes complete with terminals as required. The brackets, bolts, nuts, screws etc required for erection are also included in the scope of the Contractor.

19.0 TESTING AND COMMISSIONING

19.1 All pre/commissioning activities and works work for substation equipment shall be carried out in accordance with Employer's "Pre- Commissioning procedures for Switchyard Equipments (Doc. No. D-2-01-03-01-03)" by the contractor. This document shall be provided to the successful contractor during detailed engineering stage. Test results in the prescribed formats shall be duly filled by the contractor and shall be submitted to the Owner in soft form (CD or Pen Drive)

The Contractor shall arrange all equipments instruments and auxiliaries required for testing and commissioning of equipments alongwith calibration certificates.

19.2 GENERAL CHECKS

- (a) Check for physical damage.
- (b) Visual examination of zinc coating/plating.
- (c) Check from name plate that all items are as per order/specification.
- (d) Check tightness of all bolts, clamps and connecting terminals using torque wrenches.
- (e) For oil filled equipment, check for oil leakage, if any. Also check oil level and top up wherever necessary.
- (f) Check ground connections for quality of weld and application of zinc rich paint over weld joint of galvanised surfaces.
- (g) Check cleanliness of insulator and bushings.
- (h) All checks and tests specified by the manufacturers in their drawings and manuals as well as all tests specified in the relevant code of erection.
- (i) Check for surface finish of grading rings (Corona control ring).

19.3 STATION EARTHING

- a) Check soil resistivity
- b) Check continuity of grid wires
- c) Check earth resistance of the entire grid as well as various sections of the same.
- d) Check for weld joint and application of zinc rich paint on galvanised surfaces.
- e) Dip test on earth conductor prior to use.

SECTION - (SE)
SWITCHYARD ERECTION

19.4 AAC/ACSR STRINGING WORK, TUBULAR BUS WORK AND POWER CONNECTORS

- a) Physical check for finish
- b) Electrical clearance check
- c) Testing of torque by torque wrenches on all bus bar power connectors and other accessories.
- d) Millivolt drop test on all power connectors.
- e) Sag and tension check on conductors.

19.5 ALUMINIUM TUBE WELDING

- a) Physical check
- b) Millivolt drop test on all joints.
- c) Dye penetration test & Radiography test on 10% sample basis on weld joints.
- c) Test check on 5% sample joints after cutting the weld piece to observe any voids etc.

19.6 INSULATOR

Visual examination for finish, damage, creepage distance etc.

SECTION - (SE)
SWITCHYARD ERECTION

ANNEXURE "A"

(Testing Procedure for ACSR/AAC Conductor)

1.0 UTS Test on Stranded Conductor

Circles perpendicular to the axis of the conductor shall be marked at two places on a sample of conductor of minimum 5m length suitably compressed with dead end clamps at either end. The load shall be increased at a steady rate upto 50% of minimum specified UTS and held for one minute. The circles drawn shall not be distorted due to Relative movement of strands. Thereafter the load shall be increased at a steady rate to 100% of minimum specified UTS and held for one minute. The conductor sample shall not fail during this period. The applied load shall then be increased until the failing load is reached and the value recorded.

2.0 Corona Extinction Voltage Test

Two samples of conductor of 5m length shall be strung with a spacing of 450 mm between them at a height not exceeding 8.0 m above ground. This assembly shall be tested as per Annexure-C, Corona extinction voltage shall not be less than 510 kV (rms) & 320 KV (RMS) Line to ground for 765 kV & 400 kV respectively.

3.0 Radio Interference Voltage Test

Under the conditions as specified under (2.0) above, the conductor samples shall have radio interference voltage as indicated in the guaranteed technical particulars enclosed with. This test may be carried out with corona control rings and arcing horns. The test procedure shall be in accordance with IEC-60437.

4.0 D.C Resistance Test on Stranded Conductor

On a conductor sample of minimum 5 m length two contact clamps shall be fixed with a pre-determined bolt torque. The resistance shall be measured by a Kelvin double bridge by placing the clamps initially zero metre and subsequently one metre apart. The test shall be repeated at least five times and the average value recorded. The value obtained shall be corrected to the value at 20°C as per clause no. 12.8 of IS:398 (Part V)-1982. The resistance corrected at 20°C shall conform to the requirements of this specification.

5.0 Chemical Analysis of Zinc

Samples taken from the zinc ingots shall be chemically/spectrographically analysed. The same shall be in conformity to the requirements stated in this specification.

6.0 Chemical Analysis of Aluminium and Steel

Samples taken from the Aluminium ingots/coils/strands shall be chemically/spectrographically analysed. The same shall be in conformity to the requirements stated in this specification.

7.0 Visual Check for Joints, Scratches etc.

Conductor drums shall be rewound in the presence of the inspector. The

SECTION - (SE) **SWITCHYARD ERECTION**

inspector shall visually check for scratches, joints, etc. and that the conductor generally conform to the requirements of this specification. The length of conductor wound on the drum shall be measured with the help of counter meter during rewinding.

8.0 Dimensional Check for Steel and Aluminium Strands.

The individual strands shall be dimensionally checked to ensure that they conform to the requirements of this specification.

9.0 Check for Lay-ratios of various Layers.

The lay-ratios of various layers shall be checked to ensure that they conform to the requirements of this Specification.

10.0 Galvanising Test

The test procedure shall be as specified in IEC:60888. The material shall conform to the requirements of this Specification. The adherence of zinc shall be checked by wrapping around a mandrel four times the diameter of steel wire.

11.0 Torsion and Elongation Tests on Steel Strands

The test procedures shall be as per clause No. 10.3 of IEC:60888. In torsion test, the number of complete twists before fracture shall not be less than that indicated in the GTP. In case test sample length is less or more than 100 times the stranded diameter of the strand, the minimum number of twists will be proportioned to the length and if number comes in the fraction then it will be rounded off to next higher whole number. In elongation test, the elongation of the strand shall not be less than 4% for a gauge length of 250 mm.

12.0 Procedure Qualification test on welded Aluminium strands

Two Aluminium wires shall be welded as per the approved quality plan and shall be subjected to tensile load. The breaking strength of the welded joint of the wire shall not be less than the breaking strength of individual strands.

SECTION - (SE)
SWITCHYARD ERECTION

ANNEXURE "B"

(Testing procedure for Galvanised Steel Earthwire)

1. UTS TEST

Circles perpendicular to the axis of the earthwire shall be marked at two places on a sample of earthwire of minimum 5m length suitably compressed with dead end clamps at either end. The load shall be increased at steady rate upto 50% of UTS and held for one minute. The circles drawn shall not be distorted due to relative movement of strands. Thereafter, the load shall be increased at a steady rate to 100% of UTS and held for one minute. The earthwire sample shall not fail during this period. The applied load shall then be increased until the failing load is reached and value recorded.

2. D.C. RESISTANCE TEST

On an earthwire sample of minimum 5m length, two contact clamps shall be fixed with a predetermined Bolt torque. The resistance shall be measured by a Kelvin double-bridge by placing the clamps initially zero meter and subsequently one meter apart. The test shall be repeated at least five times and the average value recorded. The value obtained shall be corrected to the value at 20°C shall conform to the requirements of this specification.

3. Visual check for joints, scratches etc. and length of earthwire

Earthwire drums shall be rewound in the presence of the inspector. The inspector shall visually check for joints, scratches etc. and see that the earthwire generally conforms to the requirements of this specification. The length of earthwire wound on the drum shall be measured with the help of counter meter during rewinding.

4. TORSION TEST

The minimum number of twists which a single steel strand shall withstand during torsion test shall be eighteen for a length equal to 100 times the standard diameter of the strand. In case the test sample length is less or more than 100 times the standard diameter of the strand, the minimum number of twists will be proportionate to the length and if number comes in the fraction then it will be rounded off to next higher whole number.

5. DIMENSIONAL CHECK

The individual strands shall be dimensionally checked to ensure that they conform to the requirements of this specification.

6. LAY LENGTH CHECK

The lay length shall be checked to ensure that they conform to the requirements of this specification.

7. GALVANISING TEST

The test procedure shall as specified in IS:4826-1968. The material shall conform to the requirements of this specification. The adherence of zinc shall be

SECTION - (SE)
SWITCHYARD ERECTION

checked by wrapping around a mandrel four times the diameter of steel wire.

8. CHEMICAL ANALYSIS OF ZINC USED FOR GALVANIZING

Samples taken from zinc ingots shall be chemically/spectrographically analysed. The same shall be in conformity to the requirements stated in this specification.

9. CHEMICAL ANALYSIS OF STEEL

Samples taken from steel ingots/coils/strands shall be chemically/spectrographically analysed. The same shall be in conformity to the requirements stated in this specification.

SECTION - (SE)
SWITCHYARD ERECTION

ANNEXURE-C

CORONA AND RADIO INTERFERENCE VOLTAGE (RIV) TEST

1. General

Unless otherwise stipulated, all equipment together with its associated connectors, where applicable, shall be tested for external corona both by observing the voltage level for the extinction of visible corona under falling power frequency voltage and by measurement of radio interference voltage (RIV).

2. Test Levels:

The test voltage levels for measurement of external RIV and for corona extinction voltage are listed under the relevant clauses of the specification.

3. Test Methods for RIV:

3.1 RIV tests shall be made according to measuring circuit as per International Special-Committee on Radio Interference (CISPR) Publication 16-1(1993) Part -1. The measuring circuit shall preferably be tuned to frequency with 10% of 0.5 Mhz but other frequencies in the range of 0.5 MHz to 2 MHz may be used, the measuring frequency being recorded. The results shall be in microvolts.

3.2 Alternatively, RIV tests shall be in accordance with NEMA standard Publication No. 107-1964, except otherwise noted herein.

3.3 In measurement of, RIV, temporary additional external corona shielding may be provided. In measurements of RIV only standard fittings of identical type supplied with the equipment and a simulation of the connections as used in the actual installation will be permitted in the vicinity within 3.5 meters of terminals.

3.4 Ambient noise shall be measured before and after each series of tests to ensure that there is no variation in ambient noise level. If variation is present, the lowest ambient noise level will form basis for the measurements. RIV levels shall be measured at increasing and decreasing voltages of 85%, 100% and 110% of the specified RIV test voltage for all equipment unless otherwise specified. The specified RIV test voltage for 765kV, 400kV, 220kV is listed in the detailed specification together with maximum permissible RIV level in microvolts.

3.5 The metering instruments shall be as per CISPR recommendation or equivalent device so long as it has been used by other testing authorities.

3.6 The RIV measurement may be made with a noise meter. A calibration procedure of the frequency to which noise meter shall be tuned shall establish the ratio of voltage at the high voltage terminal to voltage read by noise meter.

4. Test Methods for Visible Corona [applicable for 400kV and above]

The purpose of this test is to determine the corona extinction voltage of apparatus, connectors etc. The test shall be carried out in the same manner as RIV test described above with the exception that RIV measurements are not required during test and a search technique shall be used near the onset and extinction voltage, when the test voltage is raised and lowered to determine their precise values. The test voltage shall be raised to 110% of RIV test voltage and maintained there for five minutes. In case corona inception does not take place at 110%, test shall be stopped, otherwise test shall be continued and the voltage will then be decreased slowly until all visible corona disappears. The procedure shall be repeated at least 4

SECTION - (SE) **SWITCHYARD ERECTION**

times with corona inception and extinction voltage recorded each time. The corona extinction voltage for purposes of determining compliance with the specification shall be the lowest of the four values at which visible corona (negative or positive polarity) disappears. Photographs with laboratory in complete darkness shall be taken under test conditions, at all voltage steps i.e. 85%, 100%, and 110%. Additional photographs shall be taken at corona inception and extinction voltages. At least two views shall be photographed in each case using Panchromatic film with an ASA daylight rating of 400 with an exposure of two minutes at a lens aperture of f/5.6 or equivalent. The photographic process shall be such that prints are available for inspection and comparison with conditions as determined from direct observation. Photographs shall be taken from above and below the level of connector so as to show corona on bushing, insulators and all parts of energised connectors. The photographs shall be framed such that test object essentially, fills the frame with no cut-off.

In case corona inception does not take place at 110%, voltage shall not be increased further and corona extinction voltage shall be considered adequate.

- 4.1 The test shall be recorded on each photograph. Additional photograph shall be taken from each camera position with lights on to show the relative position of test object to facilitate precise corona location from the photographic evidence.
- 4.2 In addition to photographs of the test object preferably four photographs shall be taken of the complete test assembly showing relative positions of all the test equipment and test objects. These four photographs shall be taken from four points equally spaced around the test arrangement to show its features from all sides. Drawings of the laboratory and test set up locations shall be provided to indicate camera positions and angles. The precise location of camera shall be approved by Purchaser's inspector, after determining the best camera locations by trial energisation of test object at a voltage which results in corona.
- 4.3 The test to determine the visible corona extinction voltage need not be carried out simultaneously with test to determine RIV levels.
- 4.4 However, both test shall be carried out with the same test set up and as little time duration between tests as possible. No modification on treatment of the sample between tests will be allowed. Simultaneous RIV and visible corona extinction voltage testing may be permitted at the discretion of Purchaser's inspector if, in his opinion, it will not prejudice other test.

5. Test Records:

In addition to the information previously mentioned and the requirements specified as per CISPR or NEMA 107-1964 the following data shall be included in test report:

- a) Background noise before and after test.
- b) Detailed procedure of application of test voltage.
- c) Measurements of RIV levels expressed in micro volts at each level.
- d) Results and observations with regard to location and type of interference sources detected at each step.
- e) Test voltage shall be recorded when measured RIV passes through 100 microvolts in each direction.
- f) Onset and extinction of visual corona for each of the four tests required shall be recorded.

SECTION - (SE)
SWITCHYARD ERECTION

ANNEXURE – D

A. SHORT CIRCUIT FORCES AND SPACER SPAN FOR 765KV GANTRY STRUCTURE

Sl. No.	Max. Span	Conductor Configuration	Ph-Ph Spacing	Normal Tension	SCF per Phase	Spacer span
I.	For Fault Level of 40kA/50 kA for 1 sec.					
1.	54.0 mtr	QUAD AAC BULL	15 mtr	3.96 T	5.98 T	3.5 mtr
2.	56.0 mtr	QUAD AAC BULL	15 mtr	4.52 T	6.77 T	4.0 mtr
3.	87.9 mtr	QUAD AAC BULL	15 mtr	8.35 T	11.22 T	6.5 mtr
4.	104.0 mtr	QUAD AAC BULL	15 mtr	9.00 T	12.72 T	7.5 mtr
5.	108.61 mtr	QUAD AAC BULL	15 mtr	9.00 T	12.72 T	8.0 mtr

B. SHORT CIRCUIT FORCES AND SPACER SPAN FOR 400KV GANTRY STRUCTURE

Sl. No.	Max. Span	Conductor Configuration	Ph-Ph Spacing	Normal Tension	SCF per Phase	Spacer span
I.	For Fault Level of 40 kA for 1 sec.					
1.	54 mtr	QUAD ACSR	7 mtr	4 T	5.64 T	6 mtr
2.	70 mtr	TWIN ACSR	7 mtr	4 T	5.64 T	5 mtr
3.	54 mtr	QUAD ACSR	6 mtr	4 T	5.10 T	5 mtr
4.	70 mtr	TWIN ACSR	6 mtr	4 T	5.10 T	5 mtr
5.	48 mtr	QUAD ACSR	6 mtr	4 T	4.82T	5 mtr
6.	52.5 mtr	QUAD ACSR	6 mtr	4 T	4.85T	5 mtr
7.	56.5 mtr	QUAD ACSR	6 mtr	4 T	4.88T	5 mtr
8.	52.5 mtr	TWIN ACSR	6 mtr	4 T	4.97T	5 mtr
9.	56.5 mtr	TWIN ACSR	6 mtr	4 T	5.00 T	5 mtr
II.	For Fault Level of 50 kA for 1 sec.					
1.	48 mtr	QUAD AAC BULL	6 mtr	4 T	5.10 T	4 mtr
2.	52.5 mtr	QUAD ACSR	6 mtr	4 T	5.18 T	4 mtr
3.	56.5 mtr	QUAD ACSR	6 mtr	4 T	5.20 T	4 mtr
III.	For Fault Level of 63 kA for 1 sec.					
1.	48 mtr	QUAD AAC BULL	6 mtr	4 T	6.00 T	4 mtr
2.	52.5 mtr	QUAD ACSR	6 mtr	4 T	6.33 T	4 mtr
3.	56.5 mtr	QUAD ACSR	6 mtr	4 T	6.37 T	4 mtr

SECTION - (SE)
SWITCHYARD ERECTION

ANNEXURE – D

C. SHORT CIRCUIT FORCES AND SPACER SPAN FOR 220 kV GANTRY STRUCTURE

Sl. No.	Max. Span	Conductor Configuration	Ph-Ph Spacing	Normal Tension	SCF per Phase	Spacer span
I.	For Fault Level of 40 kA for 1 sec.					
1.	54 mtr	QUAD ACSR	4.5 mtr	4 T	5.00 T	2.5 mtr
2.	54 mtr	TWIN ACSR	4.5 mtr	2 T	3.50 T	2.5 mtr
3.	74 mtr	TWIN ACSR	4.5 mtr	4 T	5.00 T	2.5 mtr
4.	54 mtr	QUAD ACSR	4.0 mtr	4 T	5.70 T	2.5 mtr
5.	54 mtr	TWIN ACSR	4.0 mtr	2 T	3.50 T	2.5 mtr
6.	74 mtr	TWIN ACSR	4.0 mtr	4 T	5.70 T	2.5 mtr
7.	48 mtr	QUAD ACSR	4.0 mtr	4 T	5.30 T	2.5 mtr
8.	52 mtr	QUAD ACSR	4.0 mtr	4 T	5.35 T	2.5 mtr
9.	68 mtr	TWIN ACSR	4.0 mtr	4 T	5.20 T	2.5 mtr
10.	56 mtr	QUAD ACSR	4.0 mtr	4 T	5.50 T	2.5 mtr
11.	72 mtr	TWIN ACSR	4.0 mtr	4 T	5.27 T	2.5 mtr
II.	For Fault Level of 50 kA for 1 sec.					
1.	48 mtr	QUAD ACSR	4.0 mtr	4 T	5.41 T	2.0 mtr
2.	52 mtr	QUAD ACSR	4.0 mtr	4 T	5.50 T	2.0 mtr
3.	36 mtr	TWIN ACSR	4.0 mtr	2 T	3.50 T	2.0 mtr

NOTE: ACSR conductor as mentioned above indicates that it is suitable for both ACSR MOOSE as well as ACSR BERSIMIS conductor.

D. SHORT CIRCUIT FORCES AND SPACER SPAN FOR 132 kV GANTRY STRUCTURE

Sl. No.	Max. Span	Conductor Configuration	Ph-Ph Spacing	Normal Tension	SCF per Phase	Spacer span
I.	For Fault Level of 31.5kA for 1 sec.					
1.	36 mtr	Twin Moose/ Zebra ACSR	3 mtr	1 T	2.15 T	2.5 mtr
2.	31.5 mtr	Twin Moose/ Zebra ACSR	2.7mtr	1 T	2.15 T	2.5 mtr
3.	48 mtr	Single Moose/ Zebra ACSR	3 mtr	1 T	2.05 T	NA
4.	42 mtr	Single Moose/ Zebra ACSR	2.7 mtr	1 T	2.03 T	NA

SECTION - (SE)
SWITCHYARD ERECTION

ANNEXURE-E

**STANDARD TECHNICAL DATA SHEETS FOR AAC/ACSR CONDUCTORS,
GS EARTHWIRE AND ALUMINIUM TUBE**

1.0 GENERAL

Employer has standardised the guaranteed technical particulars for the following AAC/ACSR conductors, Galvanised steel earthwire and aluminum tube. The contractor shall supply the conductors as per the standard GTP mentioned below. Any deviation to the following GTP shall be clearly brought out by the bidder in their bid.

1.1 Guaranteed Technical Particulars (GTP) for conductors:

A. GTP of AAC BULL and AAC TARANTULA conductor:

Sl.	Description	Unit	AAC BULL	AAC TARANTULA
1.0	Applicable Standard		IS:398	
2.0	Raw Materials			
2.1	Steel Wire / Rods			
2.1.1	Aluminium			
a)	Minimum purity of Aluminium	%	99.50	99.50
b)	Maximum copper content	%	0.04	0.04
3.0	Aluminum strands after stranding			
3.1	Diameter			
a)	Nominal	mm	4.25	5.23
b)	Maximum	mm	4.29	5.28
c)	Minimum	mm	4.21	5.18
3.2	Minimum breaking load of strand			
a)	Before stranding	KN	2.23	3.44
b)	After stranding	KN	2.12	3.27
c)	Maximum D.C. resistance of strand at 20 deg. Centigrade	Ohm /KM	3.651	3.627
3.3	Maximum resistance of 1 m length of strand at 20 deg. C	Ohm	0.00203	0.001341
4.0	AAC Conductor			
4.1. a)	Stranding		Al – 61/4.25 mm	Al – 37/ 5.23 mm
b)	Number of Strands			
i.	1st Aluminium Layer	Nos.	1	1
ii.	2nd Aluminium Layer	Nos.	6	6

SECTION - (SE)
SWITCHYARD ERECTION

ANNEXURE-E

Sl.	Description	Unit	AAC BULL		AAC TARANTULA	
iii.	3rd Aluminium Layer	Nos.	12		12	
iv.	4th Aluminium Layer	Nos.	18		18	
v.	5th Aluminium Layer	Nos.	24		-	
4.2	Sectional Area of aluminium	Sq. mm	865.36		794.80	
4.3	Total sectional area	Sq. mm	865.36		794.80	
4.4	Approximate Weight	Kg/m	2.4		2.191	
4.5	Diameter of the conductor	mm	38.25		36.60	
4.6	UTS of the conductor	kN	139 (Min.)		120 (Min.)	
4.7	Lay ratio of the conductor	mm	Max	Min	Max	Min
a)	6 wire Aluminium layer	mm	16	10	16	10
b)	12 wire Aluminium layer	mm	16	10	16	10
c)	18 wire Aluminium layer	mm	16	10	14	10
d)	24 wire Aluminium layer	mm	14	10	-	-
4.8	DC resistance of the conductor at 20°C	ohm/km	0.03340		0.03628	
4.9	Standard length of the conductor	m	1000		1000	
4.10	Tolerance on Standard length	%	(+/-) 5		(+/-) 5	
4.11	Direction of lay of outer layer		Right Hand		Right Hand	
4.12	Linear mass of the conductor					
a)	Standard	kg/km	2400		2192	
b)	Minimum	kg/km	2355		2150	
c)	Maximum	kg/km	2445		2234	
4.13	Modulus of Elasticity	Kg/sq .mm	4709 (Initial) 5869 (Final)		4709 (Initial) 5869 (Final)	
4.14	Co-efficient of Linear Expansion	Per Deg. C	23.0x10 ⁻⁶		23.0x10 ⁻⁶	
4.15	Minimum Corona Extinction Voltage	KV (rms)	508		320	
4.16	RIV at 1 Mhz	Micro volts	Less than 1000 at 508 kV (rms)		Less than 1000 at 320 kV (rms)	
5.0	Drum Dimensions		Generally conforms to IS:1778			

**SECTION - (SE)
SWITCHYARD ERECTION**

ANNEXURE-E

Sl.	Description	Unit	AAC BULL	AAC TARANTULA
a)	Flange Diameter	mm	1855	1855
b)	Traverse width	mm	925	925
c)	Barrel Diameter	mm	850	850
d)	Flange thickness	mm	50x50	50x50

B. GTP of ACSR BERSIMIS and ACSR MOOSE conductor:

Sl.	Description	Unit	ACSR BERSIMIS	ACSR MOOSE
1.0	Applicable Standard		IS:398 / IEC - 61089	
2.0	Raw Materials			
2.1	Aluminium			
a)	Minimum purity of Aluminium	%	99.50	99.50
b)	Maximum copper content	%	0.04	0.04
2.2	Steel wires/ rods			
a)	Carbon	%	0.50 to 0.85	0.50 to 0.85
b)	Manganese	%	0.50 to 1.10	0.50 to 1.10
c)	Phosphorous	%	Not more than 0.035	Not more than 0.035
d)	Sulphur	%	Not more than 0.045	Not more than 0.045
e)	Silicon	%	0.10 to 0.35 (Max.)	0.10 to 0.35 (Max.)
2.3	Zinc			
a)	Minimum purity of Zinc	%	99.95	99.95
3.0	Aluminum strands after stranding			
3.1	Diameter			
a)	Nominal	mm	4.57	3.53
b)	Maximum	mm	4.61	3.55
c)	Minimum	mm	4.53	3.51
3.2	Minimum breaking load of strand			
a)	Before stranding	KN	2.64	1.57
b)	After stranding	KN	2.51	1.49
c)	Maximum D.C. resistance of strand at 20 deg. Centigrade	Ohm/ KM	1.738	2.921
3.3	Maximum resistance of 1 m length of strand at 20 deg. C	Ohm	0.001738	0.002921

SECTION - (SE)
SWITCHYARD ERECTION

ANNEXURE-E

Sl.	Description	Unit	ACSR BERSIMIS	ACSR MOOSE
4.0	Steel strand after stranding			
4.1	Diameter			
a)	Nominal	mm	2.54	3.53
b)	Maximum	mm	2.57	3.60
c)	Minimum	mm	2.51	3.46
4.2	Minimum breaking load of strand			
a)	Before stranding	KN	6.87	12.86
b)	After stranding	KN	6.53	12.22
4.3	Galvanising			
a)	Minimum weight of zinc coating per sq.m.	gm	260	260
b)	Minimum number of dips that the galvanised strand can withstand in the standard preece test	Nos.	2 dips of one minute & 1 dip of half minute	2 dips of one minute & 1 dip of half minute
c)	Min. No. of twists in guage length equal 100 times the dia. of wire which the strand can withstand in the torsion test (after stranding)	Nos	16 (After stranding) 18 (Before stranding)	16 (After stranding) 18 (Before stranding)
5.0	ACSR Conductor			
5.1.a)	Stranding		Al -42/4.57 mm+ Steel-7/2.54 mm	Al -54/3.53 mm+ Steel-7/3.53 mm
b)	Number of Strands			
i.	Steel centre	Nos.	1	1
ii.	1st Steel Layer	Nos.	6	6
iii.	1st Aluminium Layer	Nos.	8	12
iv.	2nd Aluminium Layer	Nos.	14	18
v.	3rd Aluminium Layer	Nos.	20	24
5.2	Sectional Area of aluminium	Sq. mm	689.50	528.50
5.3	Total sectional area	Sq. mm	725.00	597.00
5.4	Approximate Weight	Kg/m	2.181	2.004
5.5	Diameter of the conductor	mm	35.05	31.77
5.6	UTS of the conductor	kN	154 (Min.)	161.20 (Min.)
5.7	Lay ratio of the conductor	mm	Max Min	Max Min

SECTION - (SE)
SWITCHYARD ERECTION

ANNEXURE-E

Sl.	Description	Unit	ACSR BERSIMIS	ACSR MOOSE
a)	Outer Steel layer	mm	24 16	18 16
b)	8/12 wire Aluminium layer	mm	17 10	14 12
c)	14/ 18 wire Aluminium layer	mm	16 10	13 11
d)	20/24 wire Aluminium layer	mm	13 10	12 10
5.8	DC resistance of the conductor at 20°C	ohm/km	0.04242	0.05552
5.9	Standard length of the conductor	m	1800	1800
5.10	Tolerance on Standard length	%	(+/-) 5	(+/-) 5
5.11	Direction of lay of outer layer	-	Right Hand	Right Hand
5.12	Linear mass of the conductor			
a)	Standard	kg/km	2181	2004
b)	Minimum	kg/km	2142	1965
c)	Maximum	kg/km	2221	2045
5.13	Modulus of Elasticity (Final State)	Kg/sq .mm		6860
5.14	Co-efficient of Linear Expansion	Per Deg. C	21.5x10 ⁻⁶	19.3x10 ⁻⁶
5.15	Minimum Corona Extinction Voltage	KV (rms)	320	320
5.16	RIV at 1 Mhz under dry condition	Micro volts	Max. 1000 at 320 kV (rms)	Max. 1000 at 320 kV (rms)
6.0	Drum Dimensions		Generally conforms to IS:1778	
a)	Flange Diameter	mm	1800	1800
b)	Traverse width	mm	950	950
c)	Barrel Diameter	mm	650	650
d)	Flange thickness	mm	50x50	50x50

C. B. GTP of ACSR ZEBRA and ACSR PANTHER conductor:

Sl.	Description	Unit	ACSR ZEBRA	ACSR PANTHER
1.0	Applicable Standard		IS:398 / IEC-61089	
2.0	Raw Materials			
2.1	Aluminium			
a)	Minimum purity of Aluminium	%	99.50	99.50

SECTION - (SE)
SWITCHYARD ERECTION

ANNEXURE-E

Sl.	Description	Unit	ACSR ZEBRA	ACSR PANTHER
b)	Maximum copper content	%	0.04	0.04
2.2	Steel wires/ rods			
a)	Carbon	%	0.50 to 0.85	0.50 to 0.85
b)	Manganese	%	0.50 to 1.10	0.50 to 1.10
c)	Phosphorous	%	Not more than 0.035	Not more than 0.035
d)	Sulphur	%	Not more than 0.045	Not more than 0.045
e)	Silicon	%	0.10 to 0.35 (Max.)	0.10 to 0.35 (Max.)
2.3	Zinc			
a)	Minimum purity of Zinc	%	99.95	99.95
3.0	Aluminum strands after stranding			
3.1	Diameter			
a)	Nominal	mm	3.18	3.00
b)	Maximum	mm	3.21	3.03
c)	Minimum	mm	3.15	2.97
3.2	Minimum breaking load of strand			
a)	Before stranding	KN	1.29	1.17
b)	After stranding	KN	1.23	1.11
3.3	Maximum resistance of 1 m length of strand at 20 deg. C	Ohm	0.003626	0.004107
4.0	Steel strand after stranding			
4.1	Diameter			
a)	Nominal	mm	3.18	3.00
b)	Maximum	mm	3.24	3.06
c)	Minimum	mm	3.12	2.94
4.2	Minimum breaking load of strand			
a)	Before stranding	KN	10.43	9.29
b)	After stranding	KN	9.91	8.85
4.3	Galvanising			
a)	Minimum weight of zinc coating per sq.m.	gm	260	260
b)	Minimum number of dips that the galvanised strand can withstand in the standard preece test	Nos.	2 dips of one minute & 1 dip of half minute	2 dips of one minute & 1 dip of half minute

SECTION - (SE)
SWITCHYARD ERECTION

ANNEXURE-E

SI.	Description	Unit	ACSR ZEBRA	ACSR PANTHER		
c)	Min. No. of twists in guage length equal 100 times the dia. of wire which the strand can withstand in the torsion test (after stranding)	Nos	16 (After stranding) 18 (Before stranding)	16 (After stranding) 18 (Before stranding)		
5.0	ACSR Conductor					
5.1.a)	Stranding		Al -54/3.18 mm+ Steel-7/3.18 mm	Al -30/3.00 mm+ Steel-7/3.00 mm		
b)	Number of Strands					
i.	Steel centre	Nos.	1	1		
ii.	1st Steel Layer	Nos.	6	6		
iii.	1st Aluminium Layer	Nos.	12	12		
iv.	2nd Aluminium Layer	Nos.	18	18		
v.	3rd Aluminium Layer	Nos.	24	NA		
5.2	Sectional Area of aluminium	Sq. mm	428.9	212.10		
5.3	Total sectional area	Sq. mm	484.5	261.50		
5.4	Approximate Weight	Kg/m	1.621	0.974		
5.5	Diameter of the conductor	Mm	28.62	21.00		
5.6	UTS of the conductor	kN	130.32 (Min.)	89.67 (Min.)		
5.7	Lay ratio of the conductor	mm	Max	Min	Max	Min
a)	Outer Steel layer	mm	28	13	28	16
b)	12 wire Aluminium layer	mm	17	10	16	10
c)	18 wire Aluminium layer	mm	16	10	14	10
d)	24 wire Aluminium layer	mm	14	10	NA	NA
5.8	DC resistance of the conductor at 20°C	ohm/km	0.06868	0.140		
5.9	Standard length of the conductor	m	1800	1800		
5.10	Tolerance on Standard length	%	(+/-) 5	(+/-) 5		
5.11	Direction of lay of outer layer		Right Hand	Right Hand		
5.12	Linear mass of the conductor					
a)	Standard	kg/km	1621	974		
b)	Minimum	kg/km	1589	954		

**SECTION - (SE)
SWITCHYARD ERECTION**

ANNEXURE-E

Sl.	Description	Unit	ACSR ZEBRA	ACSR PANTHER
		km		
c)	Maximum	kg/ km	1653	993
5.13	Modulus of Elasticity	Kg/sq .mm		8158
5.14	Co-efficient of Linear Expansion	Per Deg. C	19.3x10 ⁻⁶	17.8x10 ⁻⁶
5.15	Minimum Corona Extinction Voltage	KV (rms)	154	92
5.16	RIV at 1 Mhz	Micro volts	Less than 1000 at 154 kV (rms)	Less than 500 at 92 kV (rms)
6.0	Drum Dimensions		Generally conforms to IS:1778	
a)	Flange Diameter	mm	1850	1850
b)	Traverse width	mm	925	925
c)	Barrel Diameter	mm	650	650
d)	Flange thickness	mm	50x50	50x50

1.2 Guaranteed technical particulars of Galvanised Steel Earthwire

	Description	Unit	Standard Values
1.0	Raw Materials		
1.1	Steel wires / rods		
a)	Carbon	%	Not more than 0.55
b)	Manganese	%	0.40 to 0.90
c)	Phosphorous	%	Not more than 0.04
d)	Sulphur	%	Not more than 0.04
e)	Silicon	%	0.15 to 0.35
1.2	Zinc		
a)	Minimum purity of Zinc	%	99.95
2.0	Steel strands		
2.1	Diameter		
a)	Nominal	mm	3.66
b)	Maximum	mm	3.74
c)	Minimum	mm	3.58
2.2.	Minimum breaking load of strand		
a)	After stranding	KN	10.58
2.3	Galvanising		
a)	Minimum weight of zinc coating per sq.m. after stranding	gms.	275
b)	Minimum number of dips that the galvanized strand can withstand	Nos.	3 dips of 1 minute and

**SECTION - (SE)
SWITCHYARD ERECTION**

ANNEXURE-E

	in the standard preece test		one dip of ½ minute
c)	Minimum number of twists in a gauge length equal to 100 times diameter of wire which the strand can withstand in the torsion test, after stranding	Nos.	18
3.0	Stranded Earth wire		
3.1	UTS of Earth wire	KN	68.4 (min.)
3.2	Lay length of outer steel layer		
a)	Standard	mm	181
b)	Maximum	mm	198
c)	Minimum	mm	165
3.3	Maximum DC resistance of earth wire at 20° C	Ohm/km	3.375
3.4	Standard length of earth wire	M	2000 or actual quantity whichever is less.
3.5	Tolerance on standard length	%	±5
3.6	Direction of lay for outside layer		Right hand
3.7	Linear mass		
a)	Standard	Kg/km	583
b)	Maximum	Kg/km	552
c)	Minimum	Kg/km	600
3.8	Overall diameter	mm	10.98

1.3 Guaranteed Technical Parameters of Aluminum Tube

A. GTP for 3" IPS & 4" IPS AL. TUBE

Sl. No.	Description	3" AL. TUBE	4" AL. TUBE
1.	Size	3" IPS (EH Type)	4" IPS (EH Type)
2.	Material	Aluminium Alloy 6101 T6 conforms to 63401 WP (range 2) of IS 5082 : 1998	
3.	Chemical Composition		
i)	Cu	0.05 Max	
ii)	Mg	0.4 to 0.9	
iii)	Si	0.3 to 0.7	
iv)	Fe	0.5 Max	
v)	Mn	0.03 Max	
Vi)	Al	Remainder	
4.	Outer diameter	88.90 mm	114.2 mm
5.	Tolerance on outer diameter	+2.2 mm, - 0.0 mm	+2.2 mm, - 0.0 mm
6.	Thickness	7.62 mm	8.51 mm
7.	Tolerance on thickness	+2.2 mm, - 0.0 mm	+2.2 mm, - 0.0 mm
8.	Cross-sectional area	1945.76 sq.mm	2825.61 sq.mm
9.	Weight	5.25 kg/m	7.7 kg/m
10.	Moment of Inertia	1621589.99 mm ⁴	3972577.97 mm ⁴
11.	Section Modulus	36481.21 mm ³	69572.29 mm ³

SECTION - (SE)
SWITCHYARD ERECTION

ANNEXURE-E

12.	Minimum Ultimate Tensile Strength	20.5 Kg/sq.mm	
13.	Temperature co-efficient of resistance	0.00364 per Deg.C	
14.	Minimum Electrical Conductivity at 20 deg.C	55% of IACS	
15.	Linear Temperature Co-efficient of Expansion (20 Deg.C -200 Deg.C)	0.000023	
16.	Modulus of Elasticity	6700 Kg/sq.mm	
17.	Minimum Elongation on 50 mm	10%	
18.	Thermal Conductivity at 100 Deg.C	0.43 Calories/sec/sq.mm/cm/deg.C	
19.	Minimum 0.2% proof stress	17.34 Kg/sq.mm	
20.	Minimum Yield point	17.50 Kg/sq.mm	17.50 Kg/sq.mm
21.	Minimum Breaking Strength	20.42 Kg/sq.mm	20.42 Kg/sq.mm

B. GTP for 4.5" IPS & 5" IPS AL. TUBE

Sl. No.	Description	4.5" AL. TUBE	5" AL. TUBE
1.	Size	4.5" IPS (EH Type)	5" IPS
2.	Material	Aluminium Alloy 6101 T6 conforms to 63401 WP (range 2) of IS 5082 : 1998	
3.	Chemical Composition		
	i) Cu	0.05 Max	
	ii) Mg	0.4 to 0.9	
	iii) Si	0.3 to 0.7	
	iv) Fe	0.5 Max	
	v) Mn	0.03 Max	
	vi) Al	Remainder	
4.	Outer diameter	120.0 mm	141.3 mm
5.	Tolerance on outer diameter	+1.5 mm, - 0.0 mm	+2.8 mm, - 0.0 mm
6.	Thickness	12.0 mm	9.53 mm
7.	Tolerance on thickness	+1.0 mm, - 0.0 mm	+0.8 mm, - 0.0 mm
8.	Cross-sectional area	4071.50 sq.mm	3945.11 sq.mm
9.	Weight	10.993 kg/m	10.652 kg/m
10.	Moment of Inertia	6011958.58 mm ⁴	8610787.65 mm ⁴
11.	Section Modulus	100199.31 mm ³	121879.51 mm ³
12.	Minimum Ultimate Tensile Strength	20.5 Kg/sq.mm	
13.	Temperature co-efficient of resistance	0.00364 per Deg.C	
14.	Minimum Electrical Conductivity at 20 deg.C	55% of IACS	
15.	Linear Temperature Co-efficient of Expansion (20 Deg.C -200 Deg.C)	0.000023	
16.	Modulus of Elasticity	6700 Kg/sq.mm	
17.	Minimum Elongation on 50	10%	

SECTION - (SE)
SWITCHYARD ERECTION

ANNEXURE-E

	mm		
18.	Thermal Conductivity at 100 Deg.C	0.43 Calories/sec/sq.mm/cm/deg.C	
19.	Minimum 0.2% proof stress	17.34 Kg/sq.mm	
20	Minimum Yield point	14.50 Kg/sq.mm	17.50 Kg/sq.mm
21	Minimum Breaking Strength	17.50 Kg/sq.mm	20.42 Kg/sq.mm

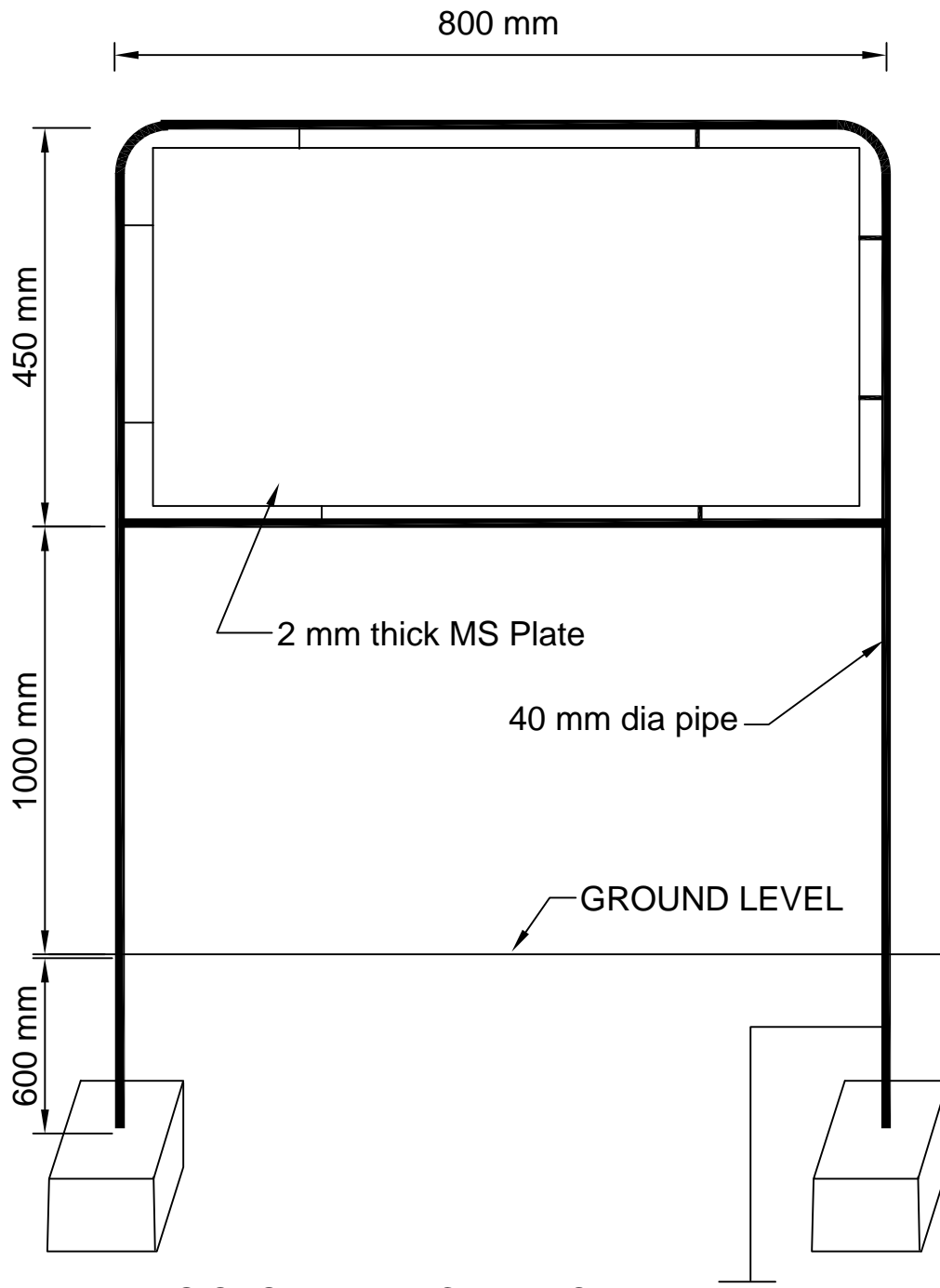

NOTE : DIMENSIONS ARE INDICATIVE ONLY.
IT MAY VARY AS PER SITE REQUIREMENT.

POWER GRID CORPORATION
OF INDIA LIMITED
(A Government of India Enterprise)



PROJECT :- STANDARD

TITLE:- STANDARD BAY NAME PLATE

<i>SK/Sankar</i>	<i>SK/Sankar</i>	18/02/2008	Drawing No.:	Rev. 00
CKD BY	PRPD BY	Date	C/ENG/STD/BAY NAME PLATE	

GENERAL INSTRUCTION FOR EARTHING:

1. Location of earthing conductors / risers shown in the earthing drawing may change to suit the site condition.
2. Two different risers of one structure/equipment shall be connected to different conductors of main earthmat.
3. Earthing conductor around the building shall be buried at a minimum distance of 1500 mm from the outer boundary of the building.
4. Minimum distance of 6000 mm shall be maintained between two treated (pipe) electrode.
5. For surge arrester, earthing lead from surge counter to to main earthmat shall be shortest in length as practically as possible. Earthing lead from surge arrester shall not be passed through any pipe.
6. No welding is allowed in the over ground earthing leads/risers if the length is less than 6m .

RELEASED FOR CONTRUCTION

POWER GRID CORPORATION OF INDIA LIMITED (A Government of India Enterprise)			 पावरग्रिड
PROJECT :- TECHNICAL SPECIFICATION- SWITCHYARD ERECTION			
TITLE:- STANDARD EARTHING DETAILS			
<i>KK Parhar</i>	<i>KK Parhar</i>	Dec-2013	Drawing No.: C/ENG/STD/EARTHINGS/09 SHEET # 1
CKD BY	PRPD BY	Date	

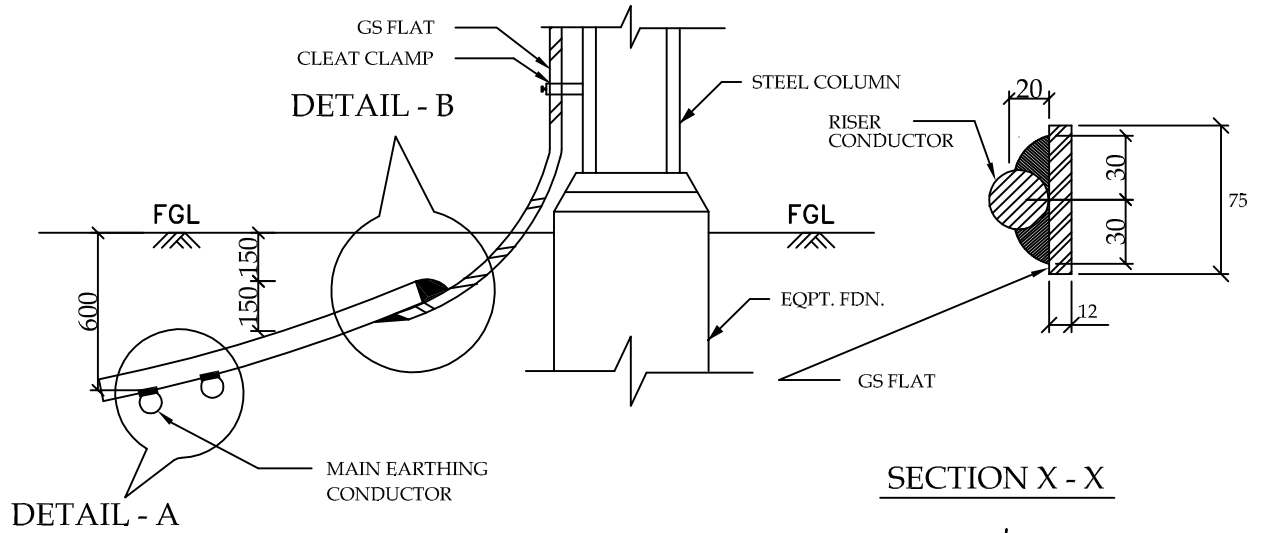

TYPICAL DETAILS OF RISER

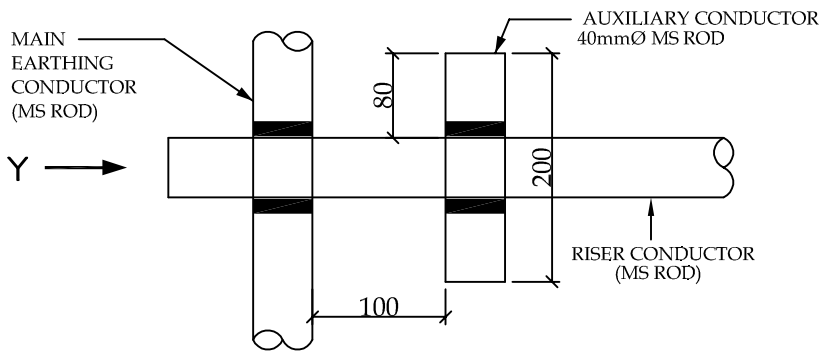

PLAN

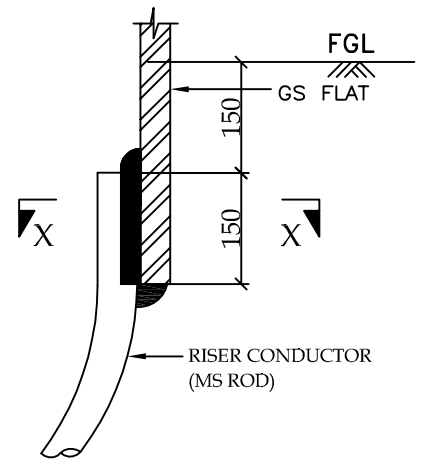

ELEVATION

DETAIL - B

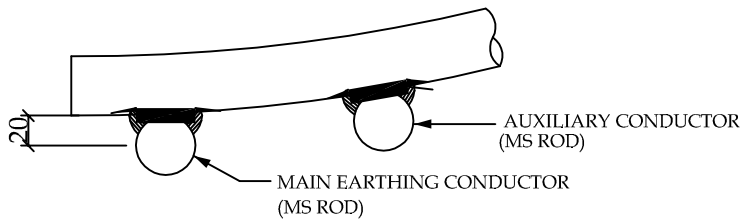

ELEVATION

DETAIL - A

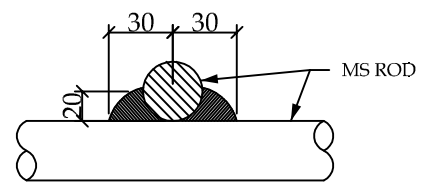

VIEW - Y

RELEASED FOR CONTRUCTION

POWER GRID CORPORATION
OF INDIA LIMITED
(A Government of India Enterprise)



PROJECT :- TECHNICAL SPECIFICATION-
SWITCHYARD ERECTION

TITLE:- STANDARD EARTHING DETAILS

<i>KK Parhar</i>	<i>KK Parhar</i>	Dec-2013	Drawing No.: C/ENG/STD/EARTHINGS/09 SHEET # 2
CKD BY	PRPD BY	Date	

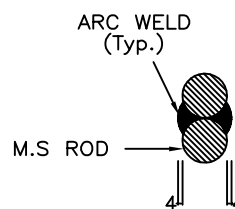
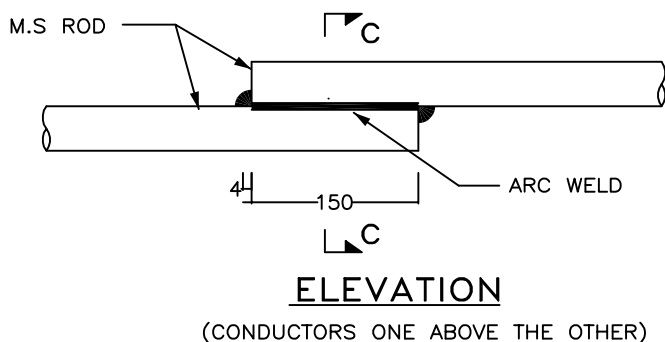
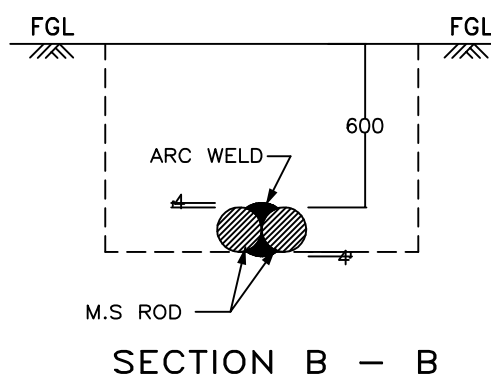
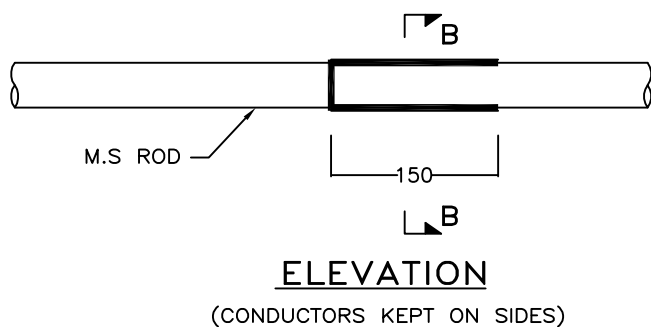
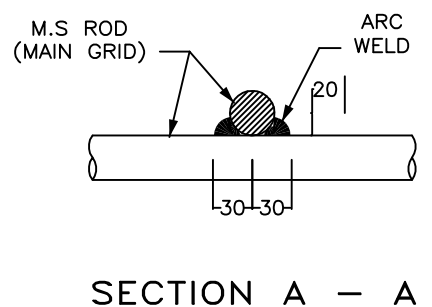
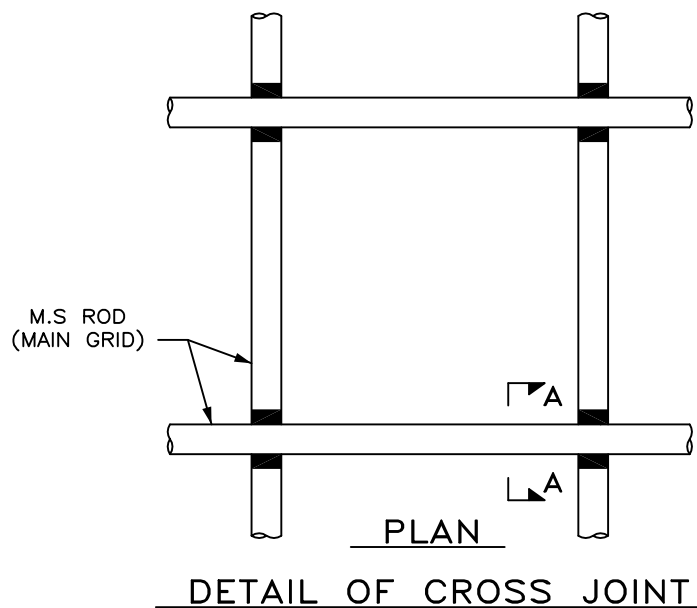

DETAIL OF LAP JOINT

RELEASED FOR CONTRUCTION

POWER GRID CORPORATION
OF INDIA LIMITED
(A Government of India Enterprise)



PROJECT :- TECHNICAL SPECIFICATION-
SWITCHYARD ERECTION

TITLE:- STANDARD EARTHING DETAILS

<i>SK Parhar</i>	<i>SK Parhar</i>	Dec-2013	Drawing No.: C/ENG/STD/EARTHINGS/09 SHEET # 3
CKD BY	PRPD BY	Date	

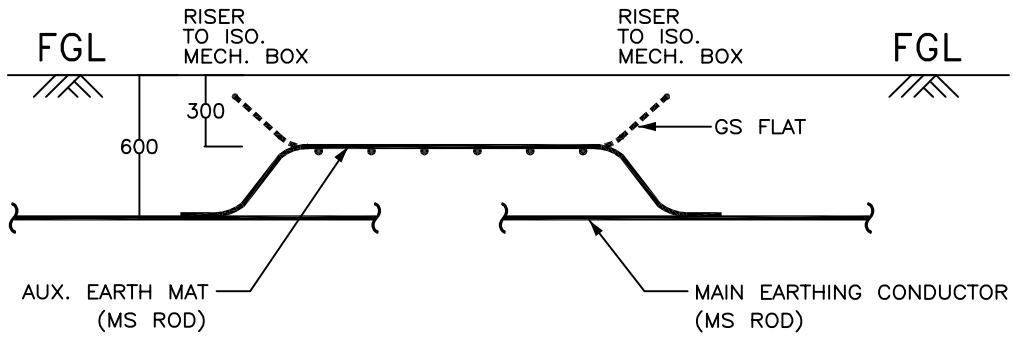

ELEVATION

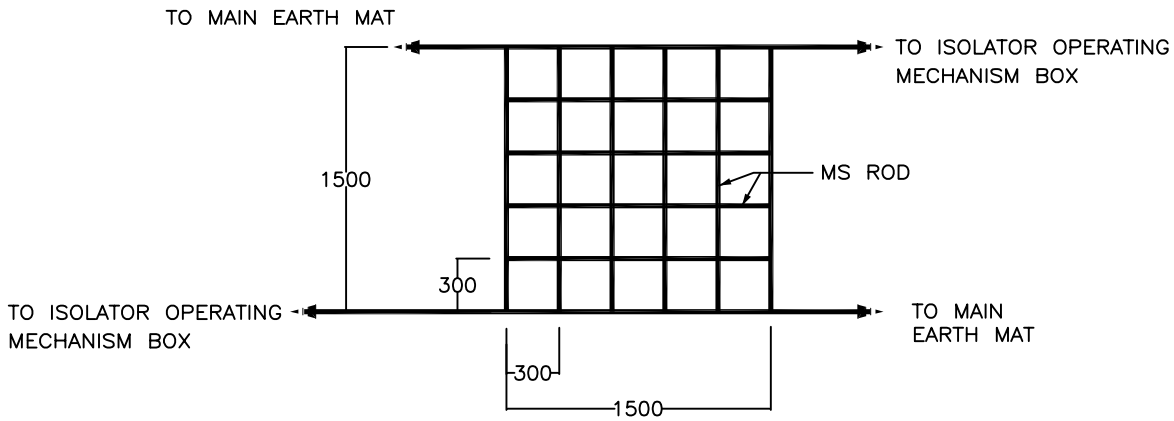

PLAN (For 220kV & above class isolators)

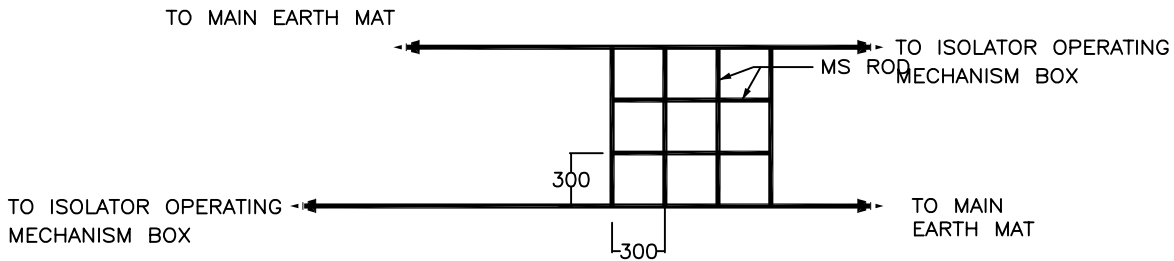

PLAN (For 132kV & below class isolators)

RELEASED FOR CONTRUCTION

POWER GRID CORPORATION
OF INDIA LIMITED
(A Government of India Enterprise)



PROJECT :- TECHNICAL SPECIFICATION-
SWITCHYARD ERECTION

TITLE:- STANDARD EARTHING DETAILS

<i>KK Parhar</i>	<i>KK Parhar</i>	Dec-2013	Drawing No.: C/ENG/STD/EARTHINGS/09 SHEET # 4
CKD BY	PRPD BY	Date	

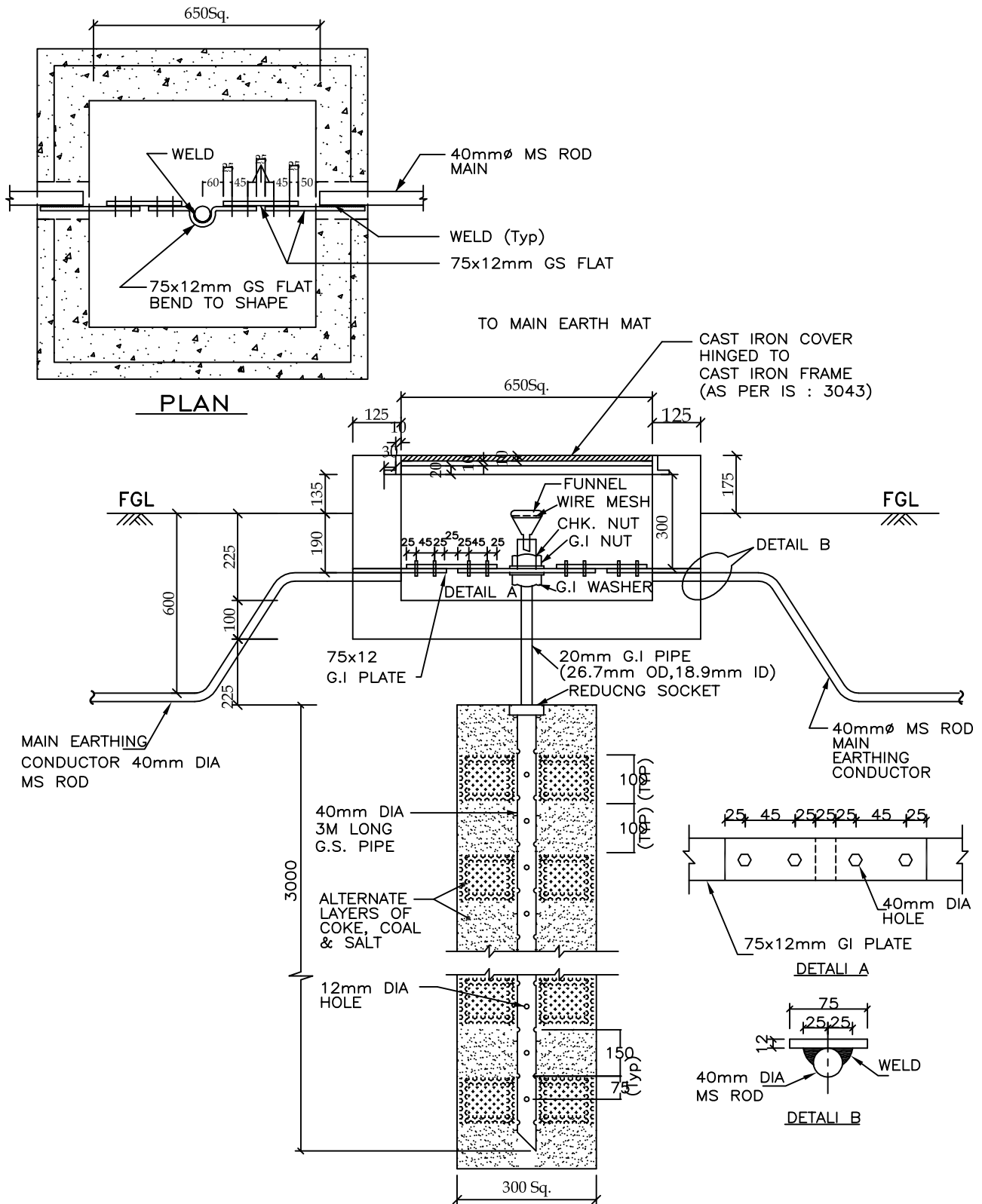

RELEASED FOR CONTRUCTION

POWER GRID CORPORATION
OF INDIA LIMITED
(A Government of India Enterprise)



PROJECT :- TECHNICAL SPECIFICATION-
SWITCHYARD ERECTION

TITLE:- STANDARD EARTHING DETAILS

<i>KK Parshar</i>	<i>KK Parshar</i>	Dec-2013	Drawing No.:
CKD BY	PRPD BY	Date	C/ENG/STD/EARTHINGS/09
			SHEET # 5

ROD ELECTRODE WITH TEST LINK FOR LM, TOWER WITH PEAK, CVT, LA

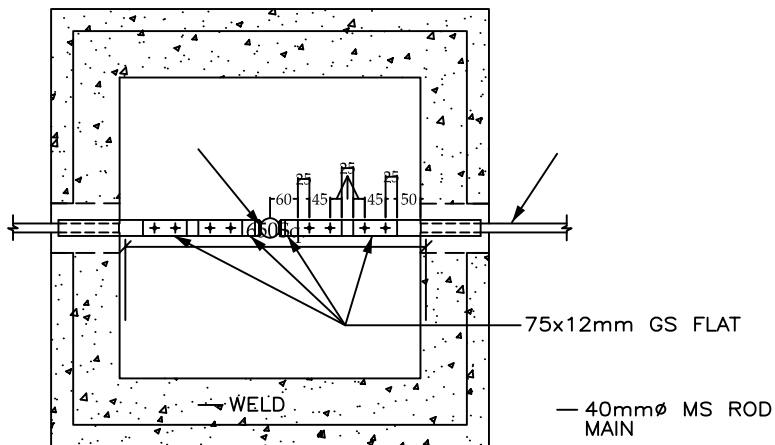

PLAN

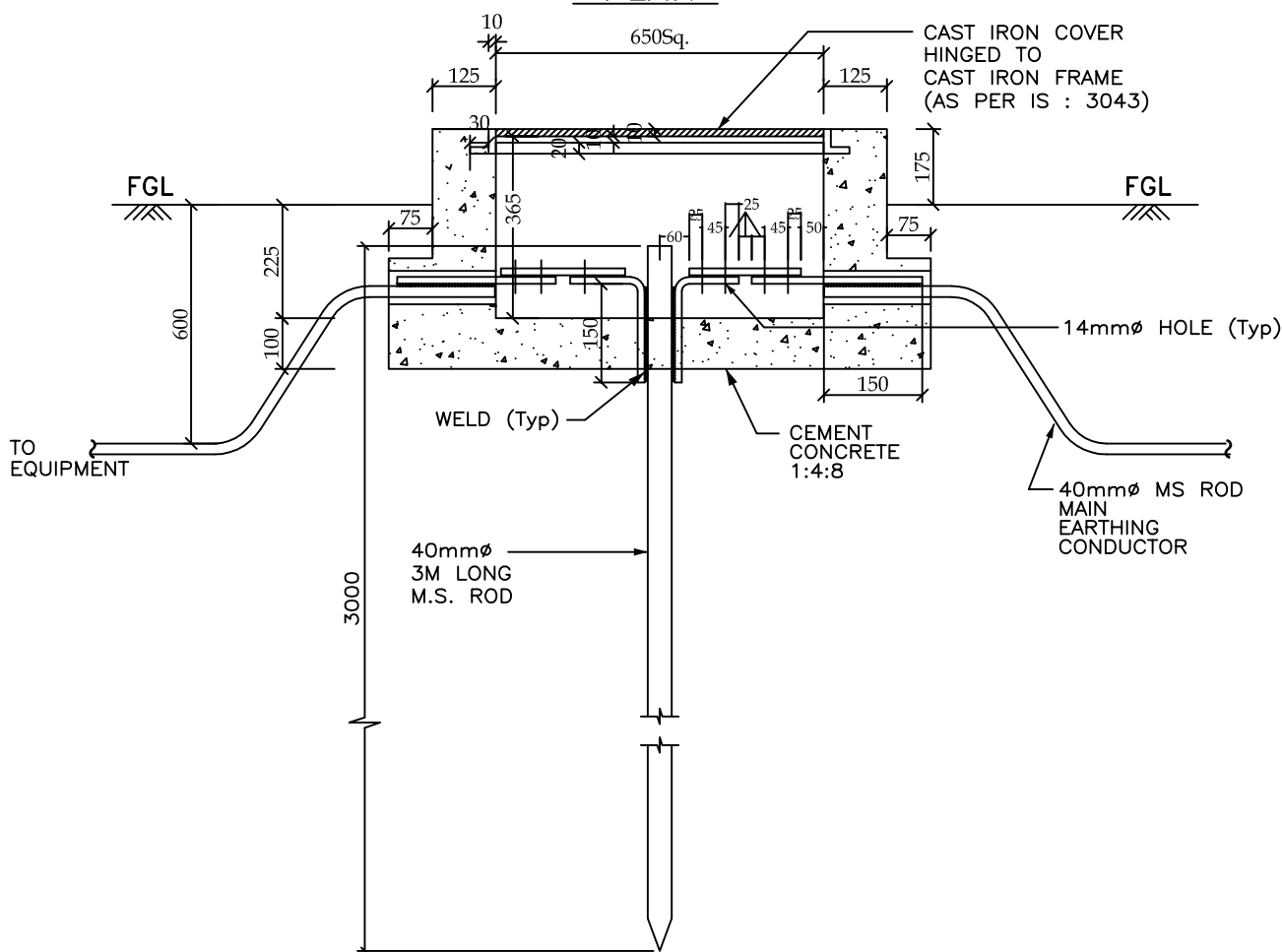

ELEVATION

RELEASED FOR CONTRUCTION

POWER GRID CORPORATION
OF INDIA LIMITED
(A Government of India Enterprise)



PROJECT :- TECHNICAL SPECIFICATION-
SWITCHYARD ERECTION

TITLE:- STANDARD EARTHING DETAILS

<i>KK Parshar</i>	<i>KK Parshar</i>	Dec-2013	Drawing No.: C/ENG/STD/EARTHINGS/09 SHEET # 6
CKD BY	PRPD BY	Date	

EARTHING OF TRANSFORMER / REACTOR

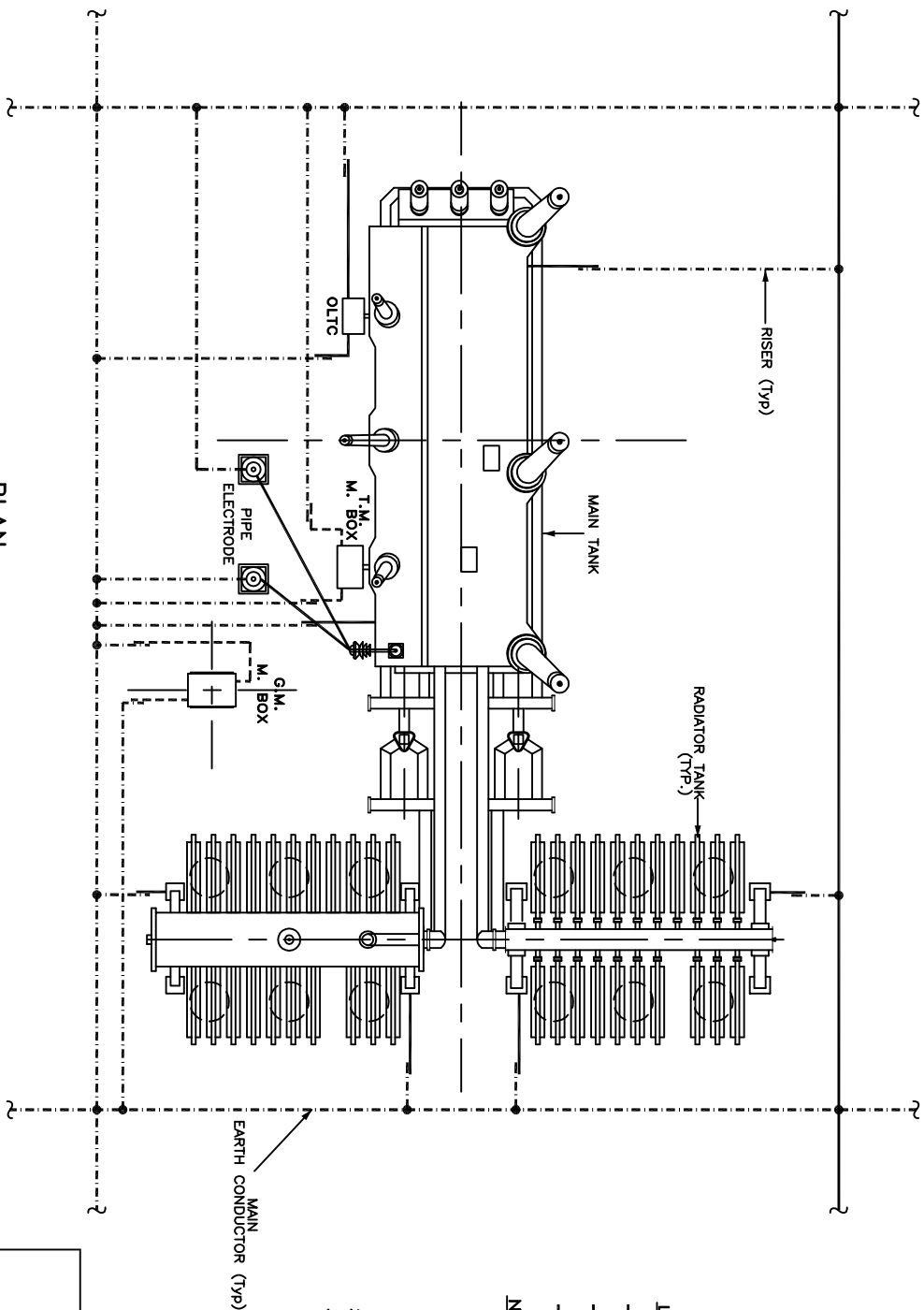

PLAN

LEGEND

- 40mm ϕ MS ROD
- 75 x 12 mm GS FLAT
- 50 x 6 mm GS FLAT

NOTES :-

1. No. OF RISERS :-
 MAIN TANK - 2 Nos.
 RADIATOR TANK - 4 Nos.
 O.L.T.C. - 2 Nos. (ICT only)
 M. BOX - 2 Nos./M. BOX
 NEUTRAL EARTH ELECTRODE - 2 Nos.
2. No. OF PIPE ELECTRODE REQUIRED = 2 Nos.
3. PYLON SUPPORTS SHALL BE EARTHED TO THE MAIN EARTHING CONDUCTOR BY GS FLAT.

RELEASED FOR CONTRUCTION

**POWER GRID CORPORATION
OF INDIA LIMITED**
(A Government of India Enterprise)



**PROJECT :- TECHNICAL SPECIFICATION-
SWITCHYARD ERECTION**

TITLE:- STANDARD EARTHING DETAILS

<i>श्रीकृष्णदास</i>	<i>श्रीकृष्णदास</i>	Dec-2013	Drawing No.:
CKD BY	PRPD BY	Date	C/ENG/STD/EARTHINGS/09
			SHEET # 7

EARTHING OF TRANSFORMER / REACTOR

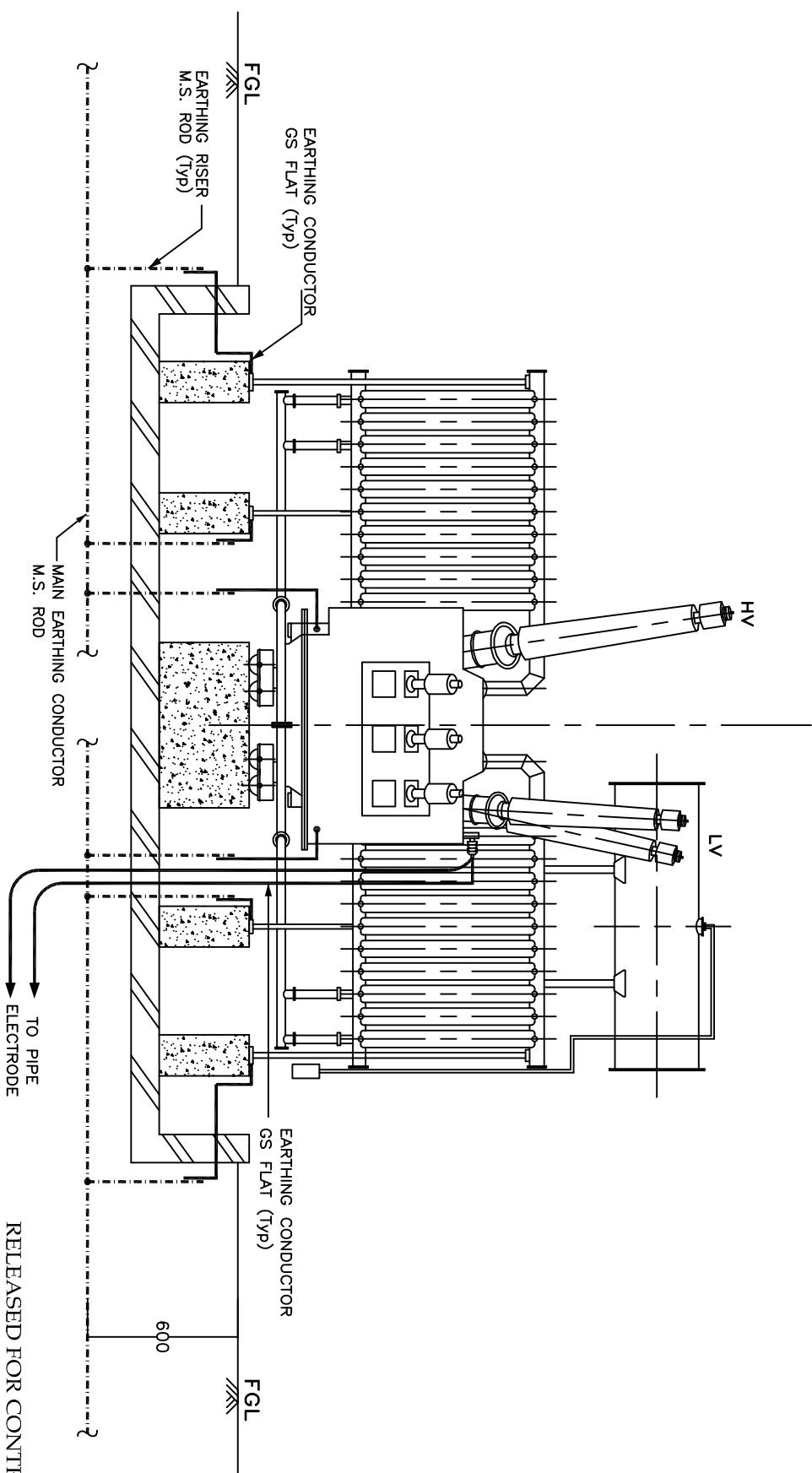

LEGEND

- 40mm ϕ MS ROD
- 75 x 12 mm GS FLAT
- - - 50 x 6 mm GS FLAT

END VIEW

RELEASED FOR CONTRUCTION

**POWER GRID CORPORATION
OF INDIA LIMITED**
(A Government of India Enterprise)



**PROJECT :- TECHNICAL SPECIFICATION-
SWITCHYARD ERECTION**

TITLE:- STANDARD EARTHING DETAILS

<i>CKD BY</i>	<i>PRPD BY</i>	<i>Date</i>	<i>Drawing No.:</i>
CKD BY	PRPD BY	Date	C/ENG/STD/EARTHINGS/09
			SHEET # 8

Dec-2013

SHEET # 8

EARTHING OF ISOLATOR

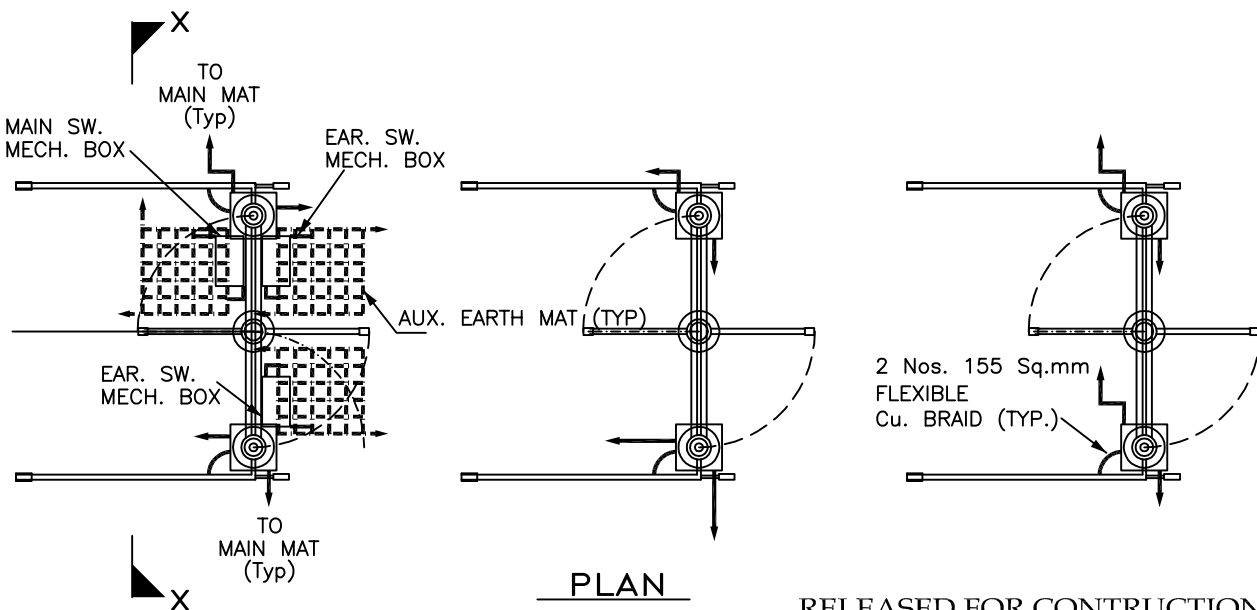
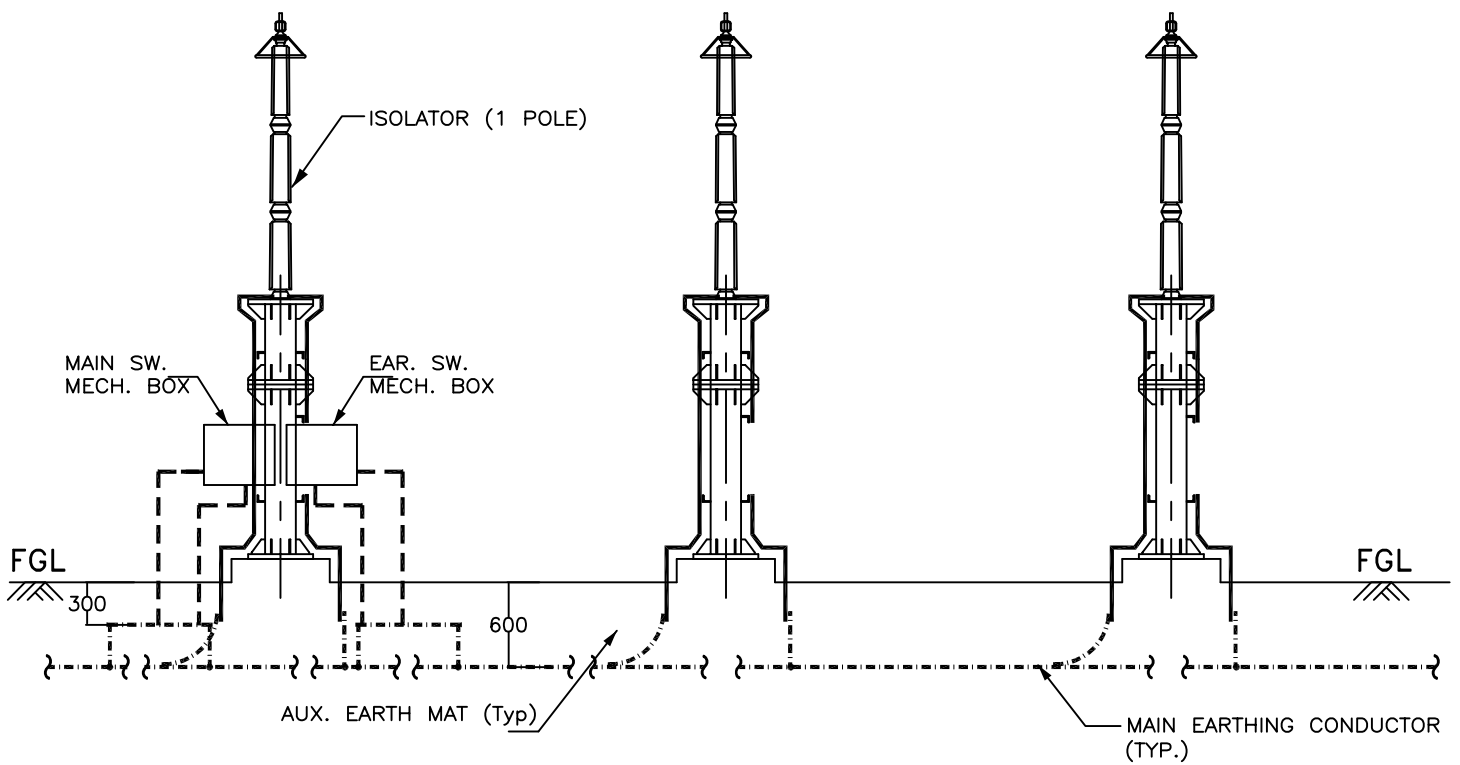

RELEASED FOR CONTRUCTION

**POWER GRID CORPORATION
OF INDIA LIMITED**
(A Government of India Enterprise)



**PROJECT :- TECHNICAL SPECIFICATION-
SWITCHYARD ERECTION**

TITLE:- STANDARD EARTHING DETAILS

<i>KK Parhar</i>	<i>KK Parhar</i>	Dec-2013	Drawing No.:
CKD BY	PRPD BY	Date	C/ENG/STD/EARTHINGS/09 SHEET # 10

EARTHING OF ISOLATOR (1 PH)

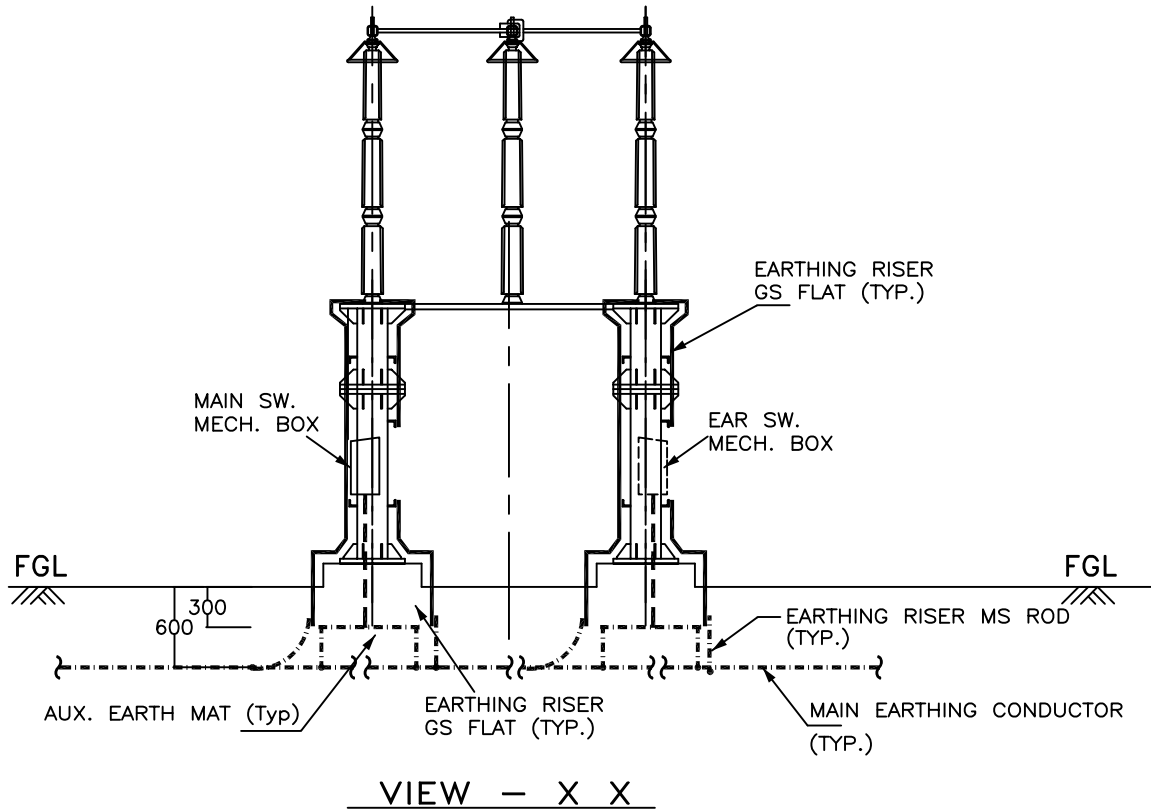

LEGEND

— · — · — · —	40mm ϕ MS ROD
- - - - -	75 x 12 mm GS FLAT
- · - · - · - · - · - · - · - · -	50 x 6 mm GS FLAT

NOTES :-

1. No. OF RISERS FOR ISOLATOR = 4 Nos. / PHASE.
2. No. OF RISERS FOR MAIN MECH. BOX = 2 Nos.
3. No. OF RISERS FOR EARTH SW. MECH. BOX = 2 Nos. / BOX.
4. No. OF AUXILIARY EARTH MAT = 1 Nos. FOR EACH MB
5. CLEAT CLAMP SHALL BE PROVIDED AT 1000mm INTERVAL.
6. NO. OF AUX. EARTH MAT IS INDICATIVE ONLY. IT SHALL BE EXECUTED AS PER ACTUAL NUMBER/POSITION OF EARTH SWITCHES.

RELEASED FOR CONTRUCTION

**POWER GRID CORPORATION
OF INDIA LIMITED**
(A Government of India Enterprise)



**PROJECT :- TECHNICAL SPECIFICATION-
SWITCHYARD ERECTION**

TITLE:- STANDARD EARTHING DETAILS

<i>KK Parshar</i>	<i>KK Parshar</i>	Dec-2013	Drawing No.:
CKD BY	PRPD BY	Date	C/ENG/STD/EARTHINGS/09 SHEET # 11

EARTHING OF CURRENT TRANSFORMER (1 PH)

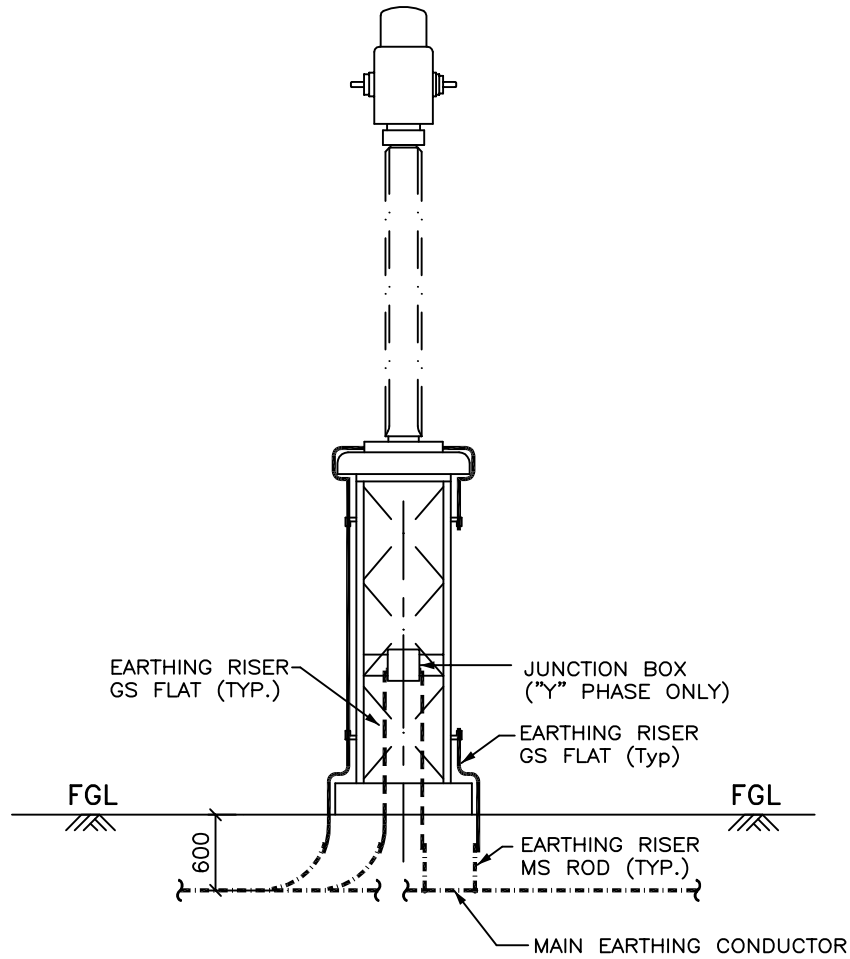

ELEVATION

LEGEND

- · — · — · — 40mm ϕ MS ROD
- 75 x 12 mm GS FLAT
- 50 x 6 mm GS FLAT

NOTES :-

1. No. OF RISERS = 2 Nos. / PHASE.
2. No. OF RISERS FOR JUN. BOX = 2 Nos.
3. CLEAT CLAMP SHALL BE PROVIDED AT 1000mm INTERVAL.

RELEASED FOR CONTRUCTION

<p>POWER GRID CORPORATION OF INDIA LIMITED (A Government of India Enterprise)</p>			 पावरग्रिड
<p>PROJECT :- TECHNICAL SPECIFICATION- SWITCHYARD ERECTION</p>			
<p>TITLE:- STANDARD EARTHING DETAILS</p>			
<i>SK Parshar</i>	<i>SK Parshar</i>	Dec-2013	Drawing No.: C/ENG/STD/EARTHINGS/09 SHEET # 12
CKD BY	PRPD BY	Date	

EARTHING OF CAPACITIVE VOLTAGE TRANSFORMER (1 PH)

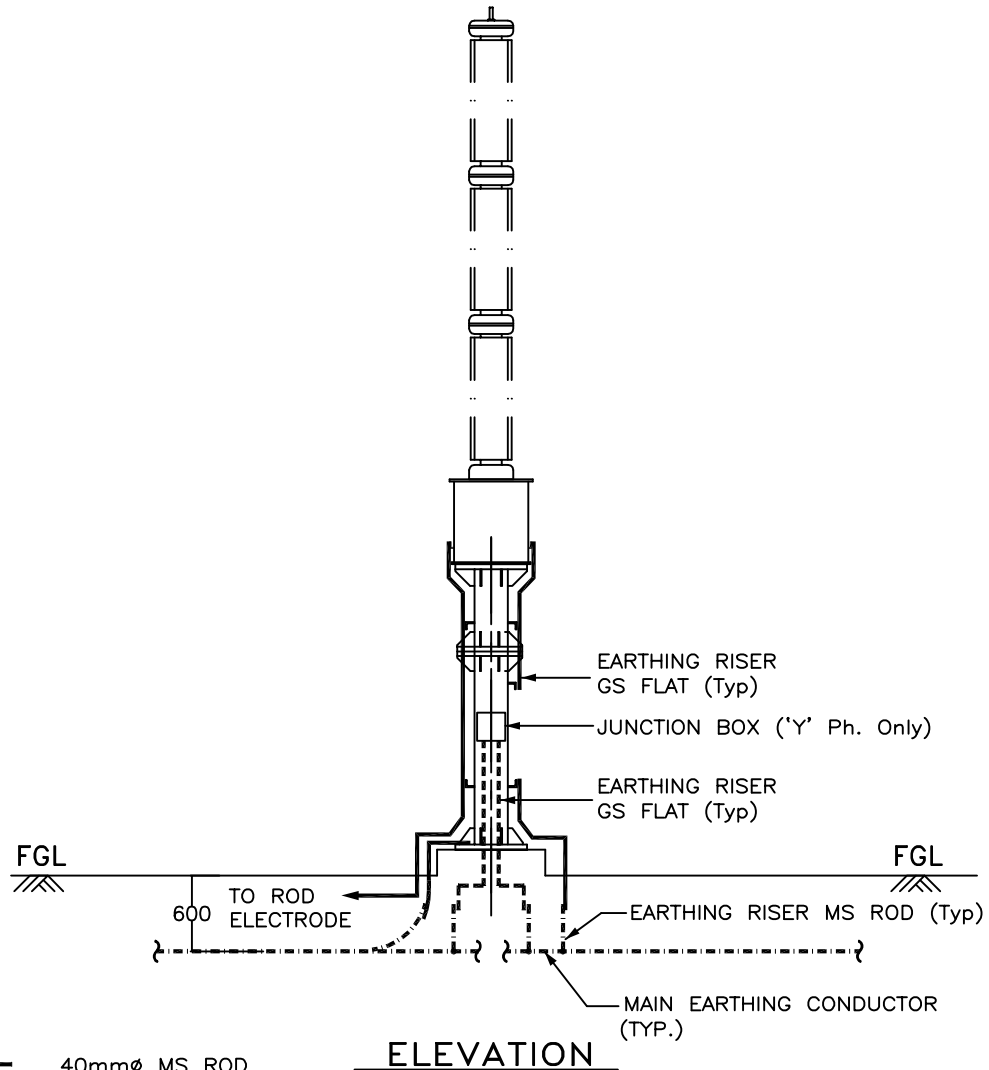

LEGEND

- 40mm ϕ MS ROD
- 75 x 12 mm GS FLAT
- 50 x 6 mm GS FLAT

NOTES :-

1. No. OF RISERS = 3 Nos. / PHASE.
2. No. OF RISERS FOR J. BOX = 2 Nos.
3. No. OF ROD ELECTRODE REQUIRED = 1 No. / PHASE.
4. CLEAT CLAMP SHALL BE PROVIDED AT 1000mm INTERVAL.

RELEASED FOR CONTRUCTION

<p>POWER GRID CORPORATION OF INDIA LIMITED (A Government of India Enterprise)</p>			<p>पावरग्रिड</p>
<p>PROJECT :- TECHNICAL SPECIFICATION- SWITCHYARD ERECTION</p>			
<p>TITLE:- STANDARD EARTHING DETAILS</p>			
<i>SK Parhar</i>	<i>SK Parhar</i>	Dec-2013	Drawing No.:
CKD BY	PRPD BY	Date	C/ENG/STD/EARTHINGS/09 SHEET # 13

EARTHING OF SURGE ARRESTER (1PH)

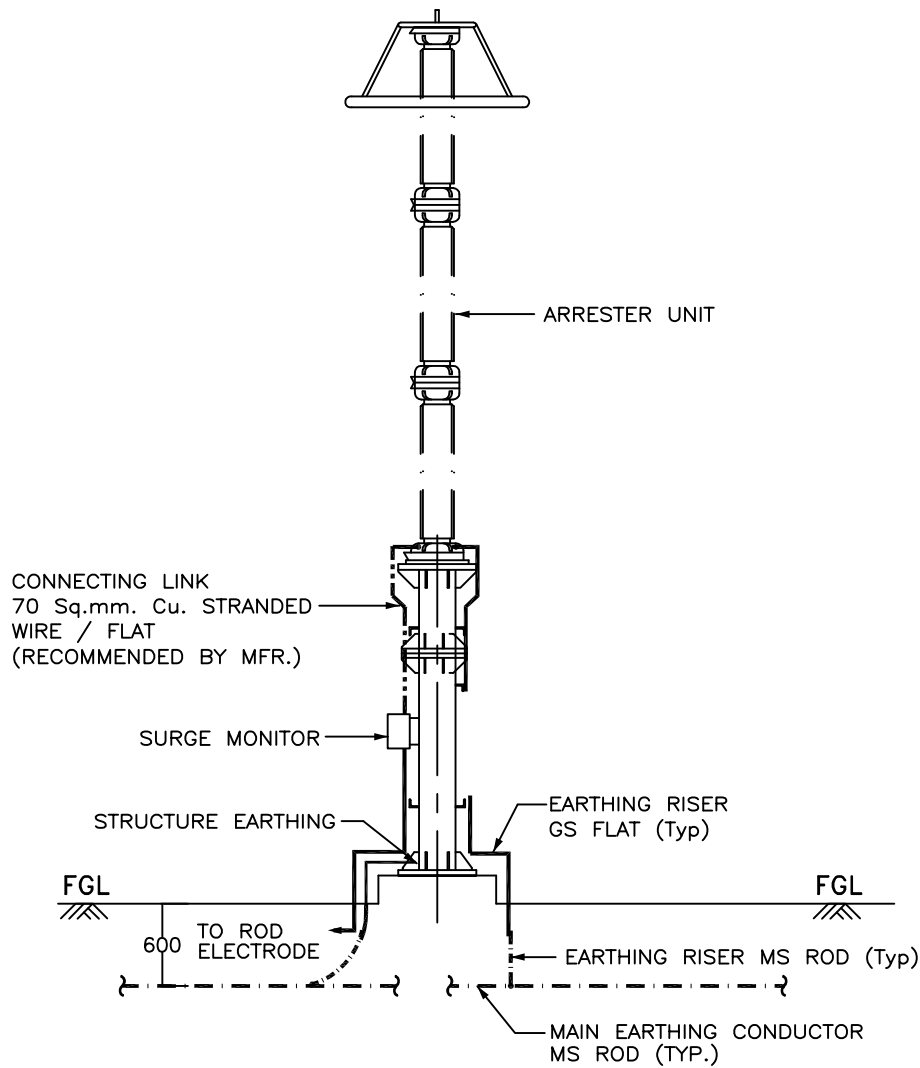

ELEVATION

LEGEND

- · — · — · — · — · — · — 40mm ϕ MS ROD
- 75 x 12 mm GS FLAT

NOTES :-

- 1 . No. OF RISERS = 3 Nos. / PHASE.
- 2 . No. OF ROD ELECTRODE REQUIRED = 1 No. / PHASE.
- 3 . CLEAT CLAMP SHALL BE PROVIDED AT 1000mm INTERVAL.

RELEASED FOR CONTRUCTION

POWER GRID CORPORATION OF INDIA LIMITED (A Government of India Enterprise)			 पावरग्रिड
PROJECT :- TECHNICAL SPECIFICATION- SWITCHYARD ERECTION			
TITLE:- STANDARD EARTHING DETAILS			
<i>SK Parshar</i>	<i>SK Parshar</i>	Dec-2013	Drawing No.: C/ENG/STD/EARTHINGS/09 SHEET # 14
CKD BY	PRPD BY	Date	

EARTHING OF WAVE TRAP (1PH)

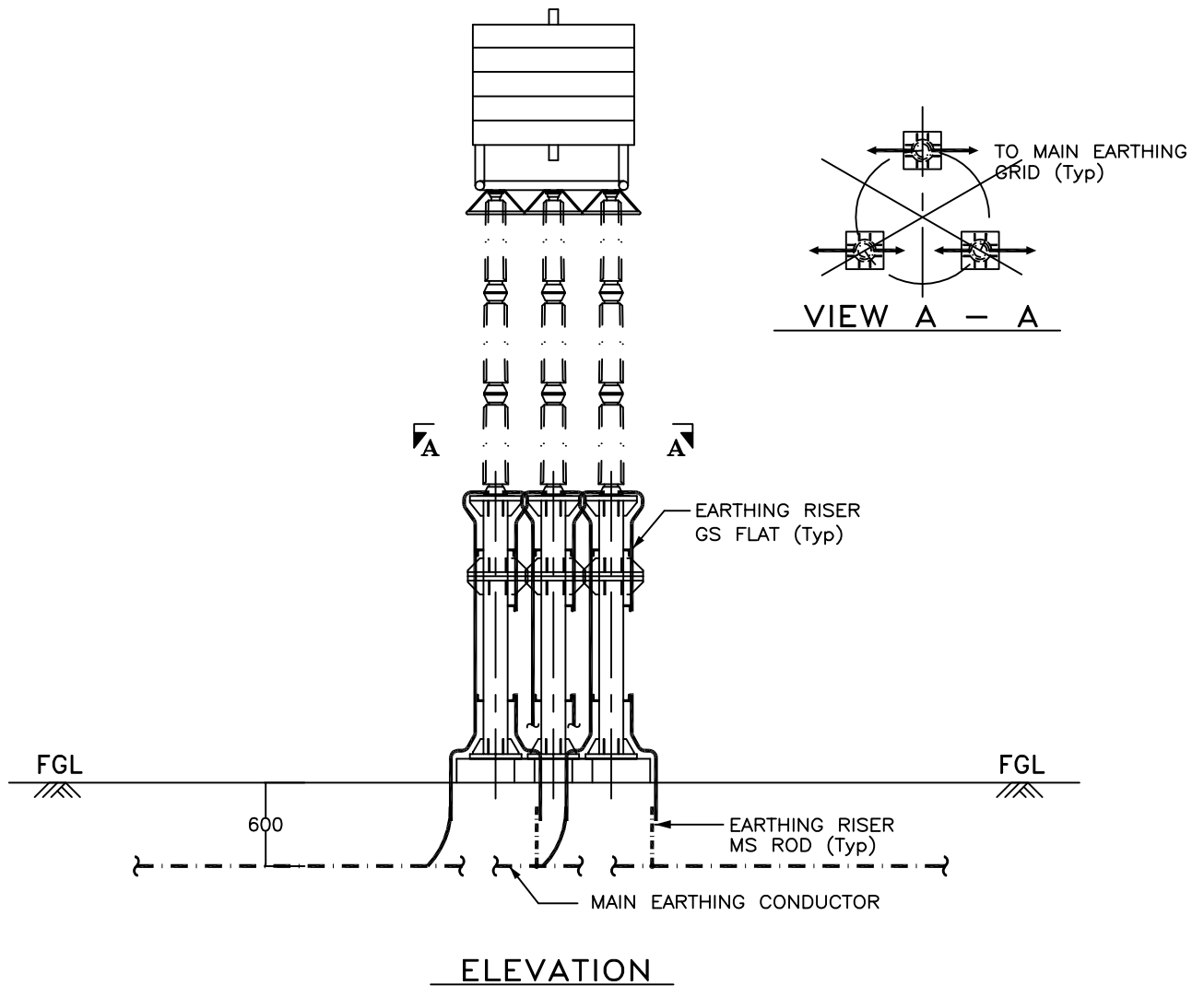

LEGEND

- · — · — · — 40mm ϕ MS ROD
- 75 x 12 mm GS FLAT

NOTE :-

1. No. OF RISERS = 6 Nos. / PHASE.
2. CLEAT CLAMP SHALL BE PROVIDED AT 1000mm INTERVAL.

RELEASED FOR CONTRUCTION

POWER GRID CORPORATION OF INDIA LIMITED <small>(A Government of India Enterprise)</small>			 पावरग्रिड
PROJECT :- TECHNICAL SPECIFICATION- SWITCHYARD ERECTION			
TITLE:- STANDARD EARTHING DETAILS			
<i>KK Parhar</i>	<i>KK Parhar</i>	Dec-2013	Drawing No.: C/ENG/STD/EARTHINGS/09 SHEET # 15
CKD BY	PRPD BY	Date	

EARTHING OF POST INSULATOR (1PH)

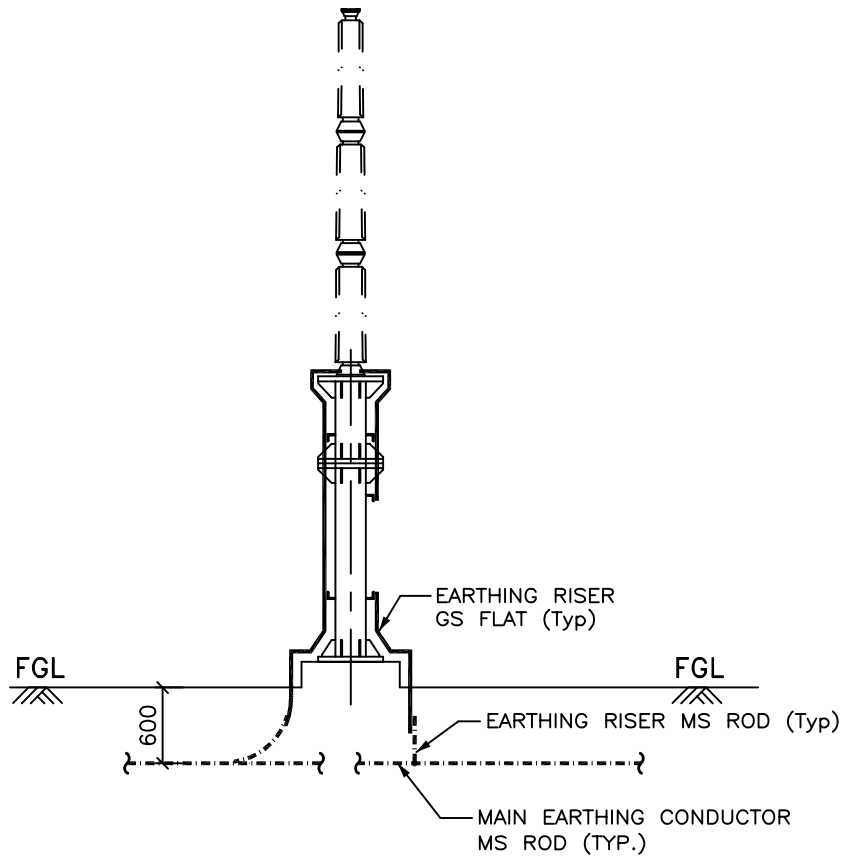

ELEVATION

LEGEND

- 40mm ϕ MS ROD
 75 x 12 mm GS FLAT

NOTES :-

1. No. OF RISERS = 2 Nos. / PHASE.
2. CLEAT CLAMP SHALL BE PROVIDED AT 1000mm INTERVAL.

RELEASED FOR CONTRUCTION

**POWER GRID CORPORATION
 OF INDIA LIMITED**
 (A Government of India Enterprise)



PROJECT :- TECHNICAL SPECIFICATION-
SWITCHYARD ERECTION

TITLE:- STANDARD EARTHING DETAILS

<i>KK Parhar</i>	<i>KK Parhar</i>	Dec-2013	Drawing No.: C/ENG/STD/EARTHINGS/09 SHEET # 16
CKD BY	PRPD BY	Date	

TANDEM ISOLATOR

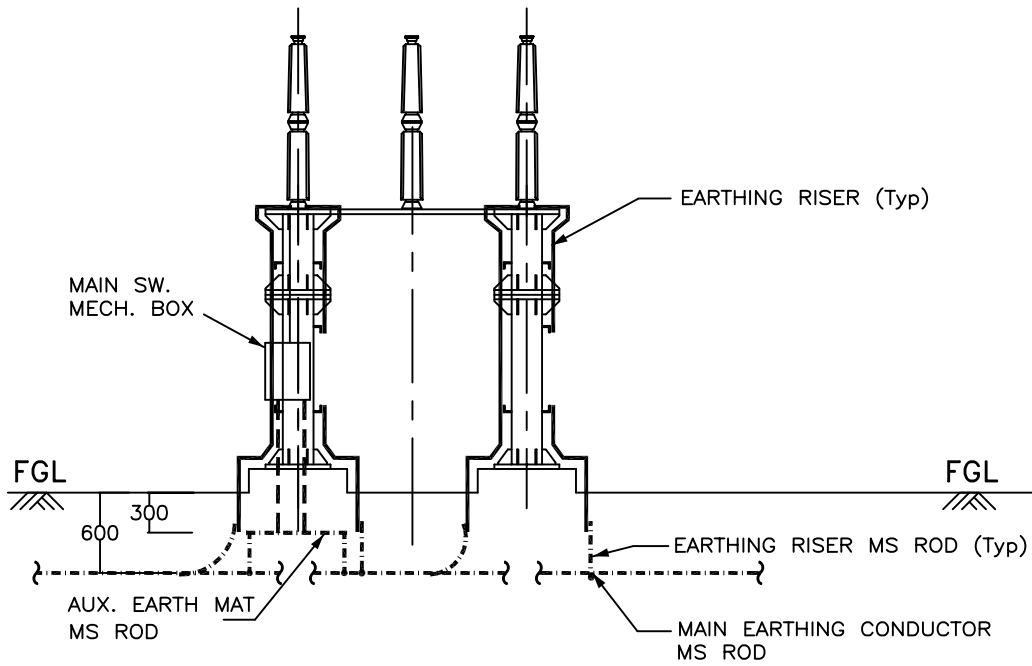

VIEW - X X

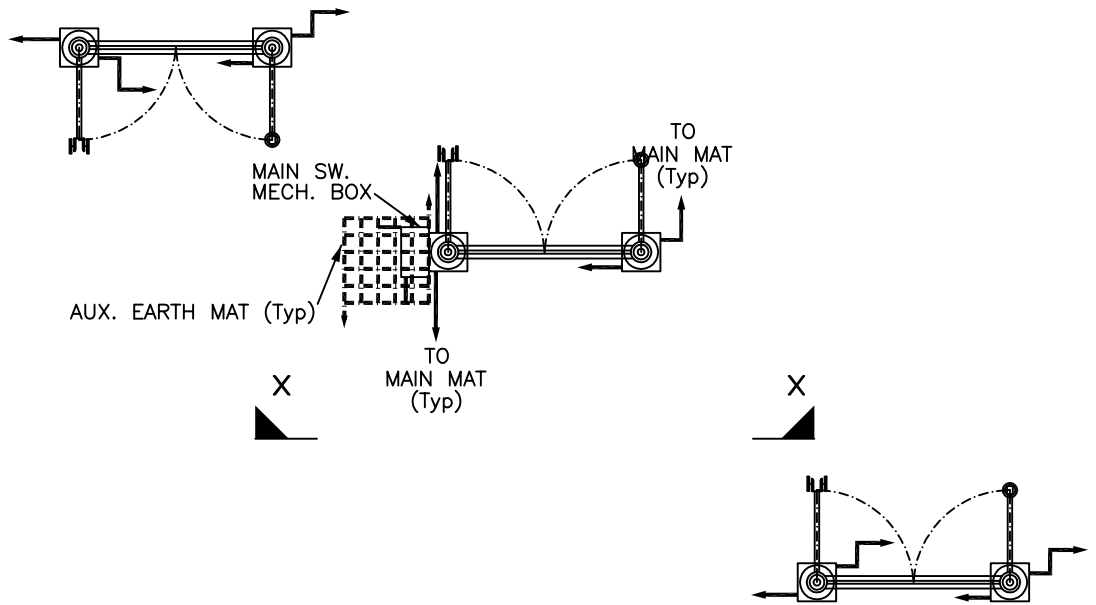

PLAN

RELEASED FOR CONTRUCTION

POWER GRID CORPORATION
OF INDIA LIMITED
(A Government of India Enterprise)



PROJECT :- TECHNICAL SPECIFICATION-
SWITCHYARD ERECTION

TITLE:- STANDARD EARTHING DETAILS

<i>SK Parshar</i>	<i>SK Parshar</i>	Dec-2013	Drawing No.: C/ENG/STD/EARTHINGS/09 SHEET # 17
CKD BY	PRPD BY	Date	

EARTHING OF LIGHTNING MAST

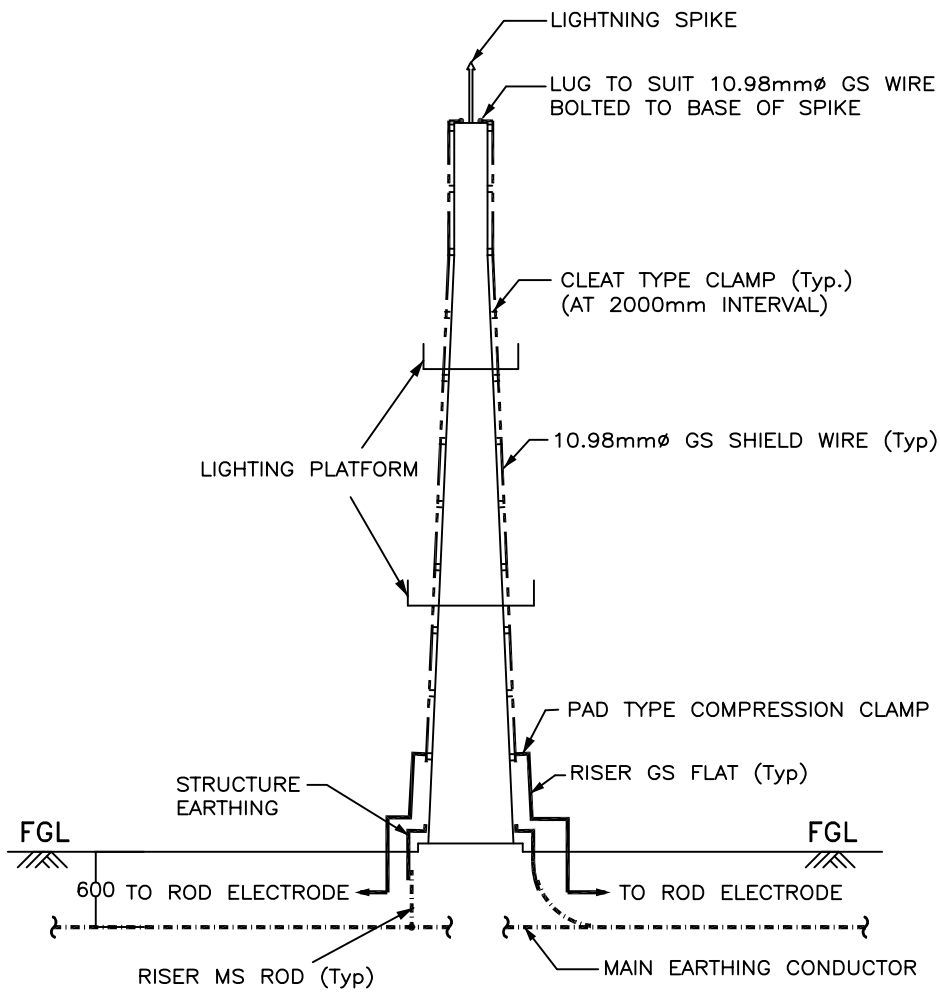

NOTES :-

1. No. OF RISERS = 4 Nos.
2. No. OF ROD ELECTRODE REQUIRED = 2 Nos.
3. No. OF PAD TYPE CLAMP = 2 Nos.

LEGEND

- 40mm ϕ MS ROD
- 75 x 12 mm GS FLAT

RELEASED FOR CONTRUCTION

<p>POWER GRID CORPORATION OF INDIA LIMITED (A Government of India Enterprise)</p>			
<p>PROJECT :- TECHNICAL SPECIFICATION- SWITCHYARD ERECTION</p>			
<p>TITLE:- STANDARD EARTHING DETAILS</p>			
<i>NK Parhar</i>	<i>NK Parhar</i>	Dec-2013	Drawing No.:
CKD BY	PRPD BY	Date	C/ENG/STD/EARTHINGS/09 SHEET # 18

EARTHING OF TOWER WITH PEAK

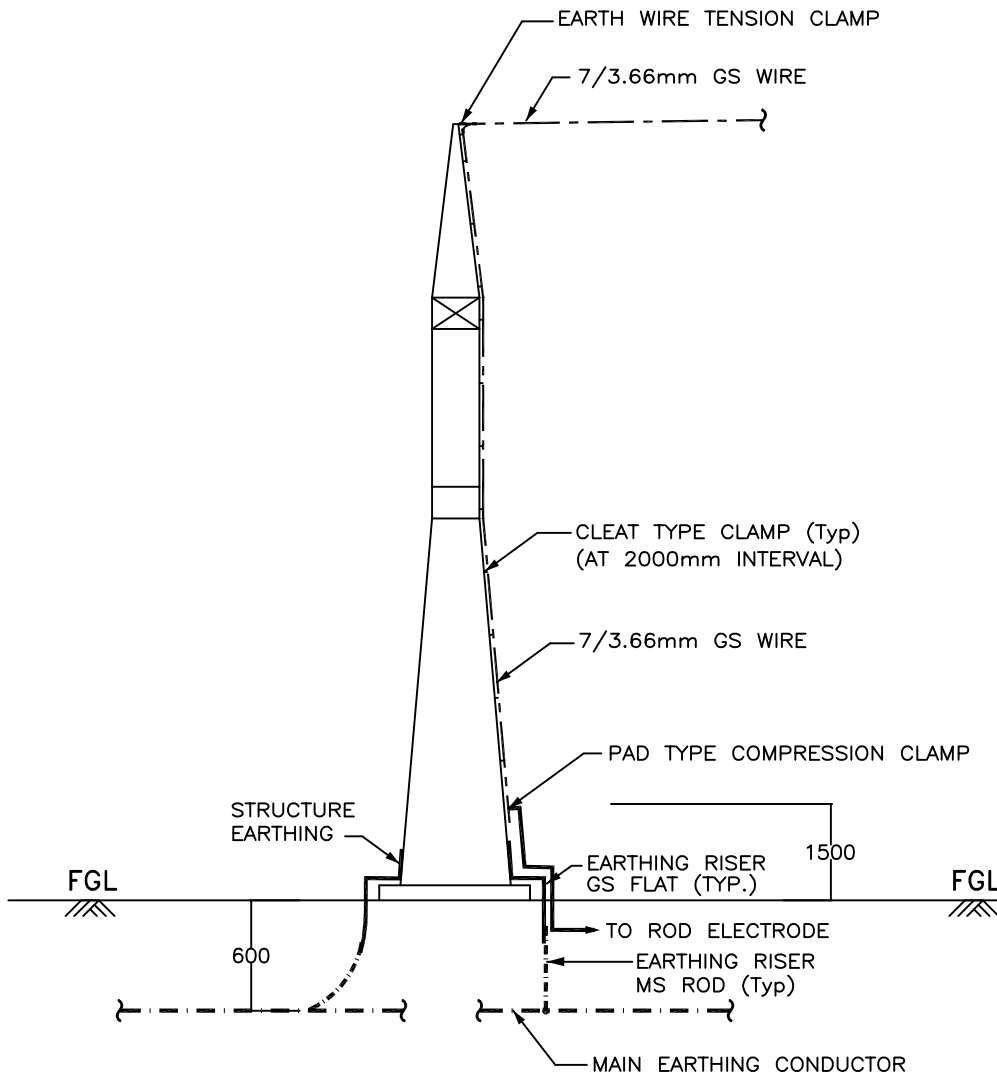

ELEVATION

LEGEND

- 40mm ϕ MS ROD
- 75 x 12 mm GS FLAT

NOTES :-

1. No. OF RISERS = 3 Nos.
2. No. OF ROD ELECTRODE REQUIRED = 1 No.
3. No. OF PAD TYPE CLAMP = 1 No.

RELEASED FOR CONTRUCTION

**POWER GRID CORPORATION
OF INDIA LIMITED**
(A Government of India Enterprise)



PROJECT :- TECHNICAL SPECIFICATION-
SWITCHYARD ERECTION

TITLE:- STANDARD EARTHING DETAILS

<i>SK Parshar</i>	<i>SK Parshar</i>	Dec-2013	Drawing No.:
CKD BY	PRPD BY	Date	C/ENG/STD/EARTHINGS/09 SHEET # 19

EARTHING OF TOWER WITHOUT PEAK

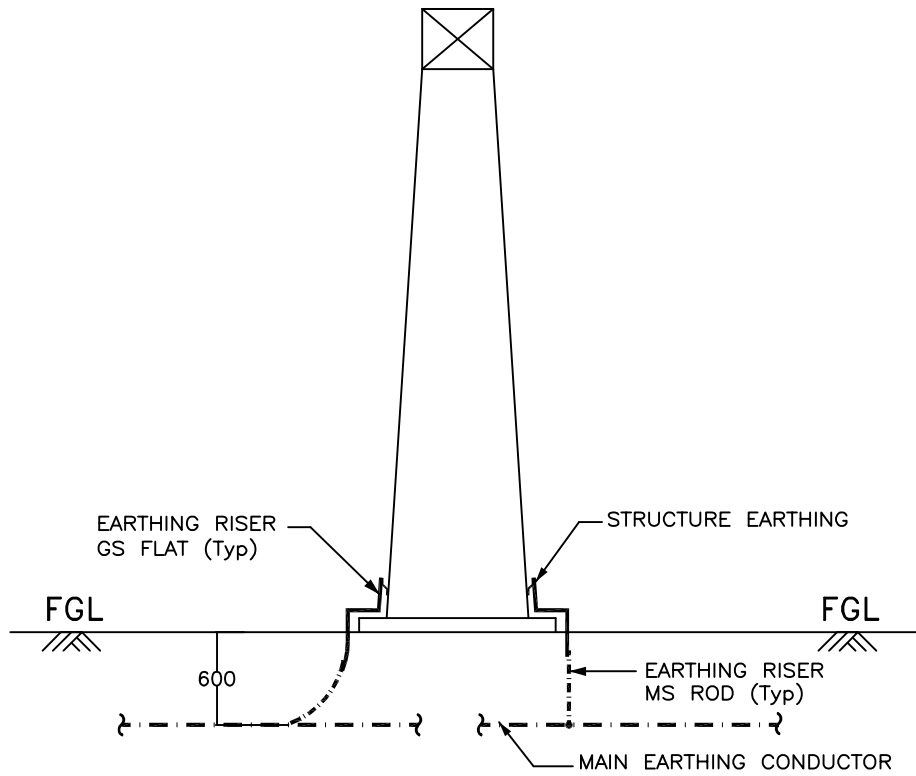

ELEVATION

LEGEND

- 40mm ϕ MS ROD
- 75 x 12 mm GS FLAT

NOTES :-

1. No. OF RISERS = 2 Nos.

RELEASED FOR CONTRUCTION

POWER GRID CORPORATION OF INDIA LIMITED <small>(A Government of India Enterprise)</small>			 पावरग्रिड
PROJECT :- TECHNICAL SPECIFICATION- SWITCHYARD ERECTION			
TITLE:- STANDARD EARTHING DETAILS			
<i>SK Parhar</i>	<i>SK Parhar</i>	Dec-2013	Drawing No.: C/ENG/STD/EARTHINGS/09 SHEET # 20
CKD BY	PRPD BY	Date	

EARTHING OF BAY MARSHALLING BOX

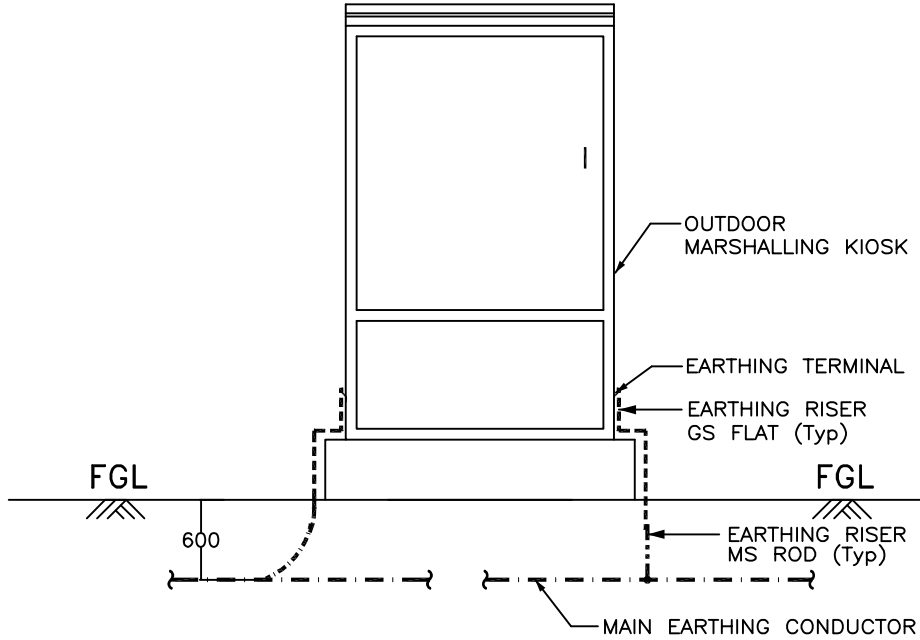

ELEVATION

LEGEND

- 40mm ϕ MS ROD
- 75 x 12 mm GS FLAT
- 50 x 6 mm GS FLAT

NOTE :-

1. No. OF RISERS = 2 Nos.

RELEASED FOR CONTRUCTION

POWER GRID CORPORATION OF INDIA LIMITED <small>(A Government of India Enterprise)</small>			 पावरग्रिड
PROJECT :- TECHNICAL SPECIFICATION- SWITCHYARD ERECTION			
TITLE:- STANDARD EARTHING DETAILS			
<i>CKD</i>	<i>PRPD</i>	Dec-2013	Drawing No.: C/ENG/STD/EARTHINGS/09 SHEET # 21
CKD BY	PRPD BY	Date	

EARTHING OF RAIL TRACK

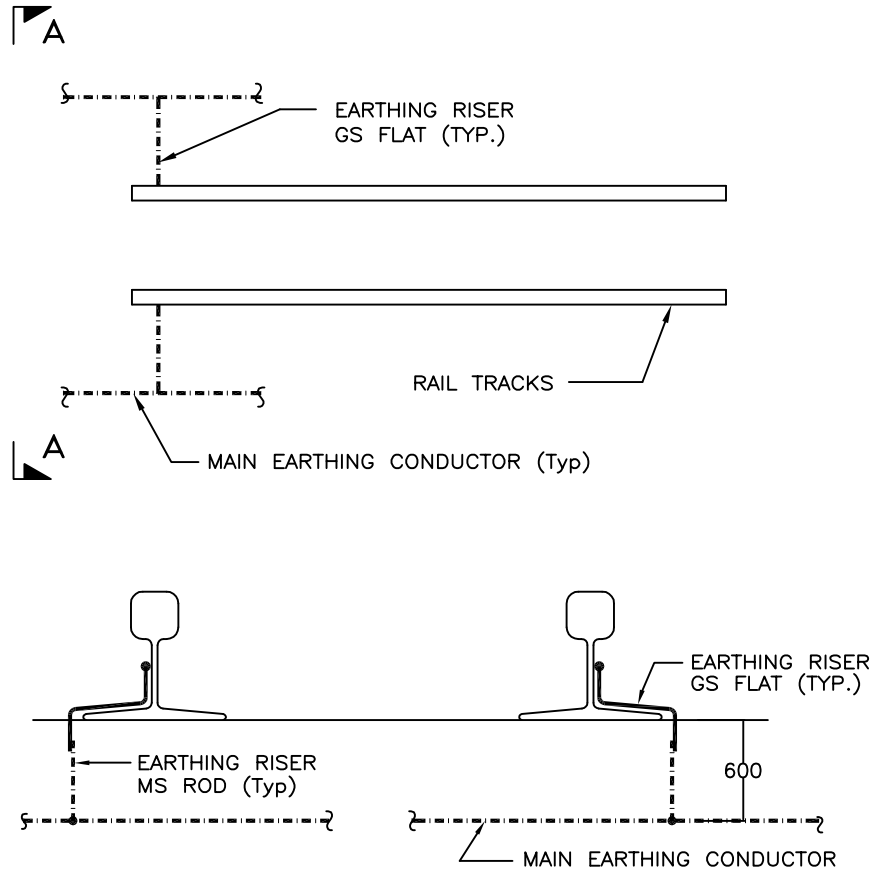

SECTION A - A

LEGEND

- 40mm ϕ MS ROD
- 75 x 12 mm GS FLAT

NOTES :-

1. EACH RAIL SHALL BE EARTHED AT 30M INTERVAL AND ALSO AT BOTH ENDS.

RELEASED FOR CONTRUCTION

**POWER GRID CORPORATION
OF INDIA LIMITED**
(A Government of India Enterprise)



**PROJECT :- TECHNICAL SPECIFICATION-
SWITCHYARD ERECTION**

TITLE:- STANDARD EARTHING DETAILS

<i>KK Parhar</i>	<i>KK Parhar</i>	Dec-2013	Drawing No.: C/ENG/STD/EARTHINGS/09 SHEET # 22
CKD BY	PRPD BY	Date	

EARTHING OF CABLE TRENCH

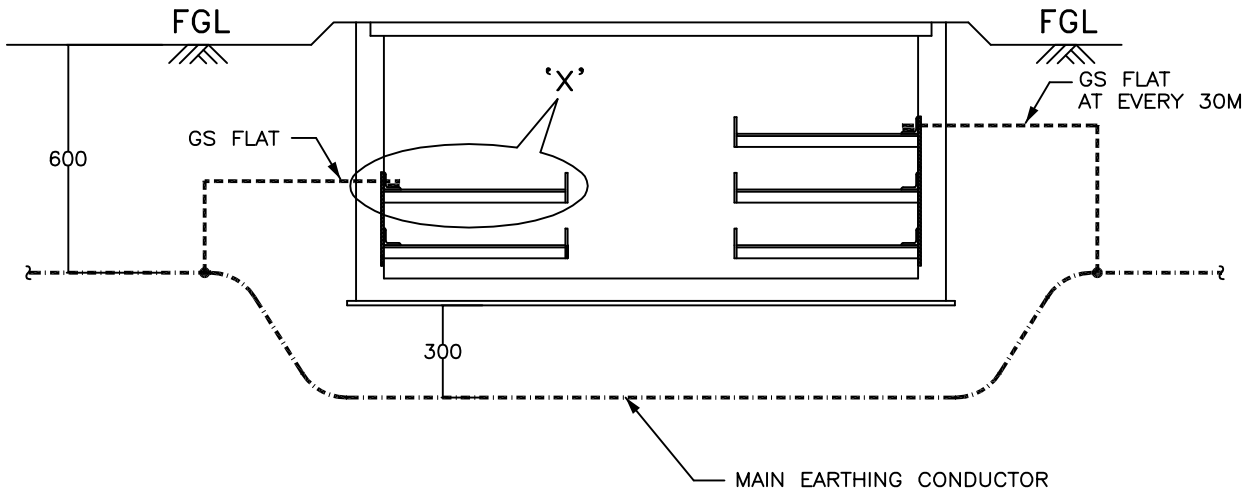

TYPICAL CROSS SECTION OF CABLE TRENCH

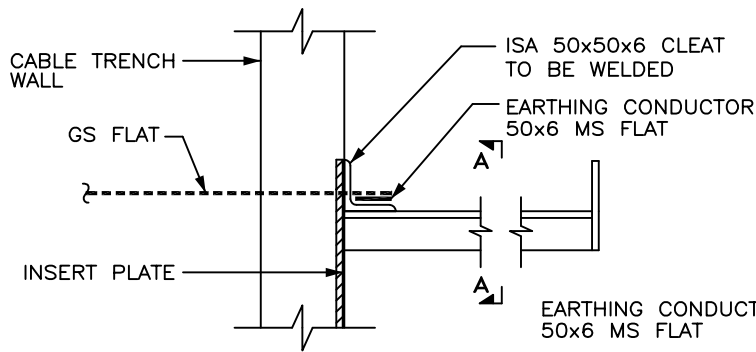

DETAIL - X

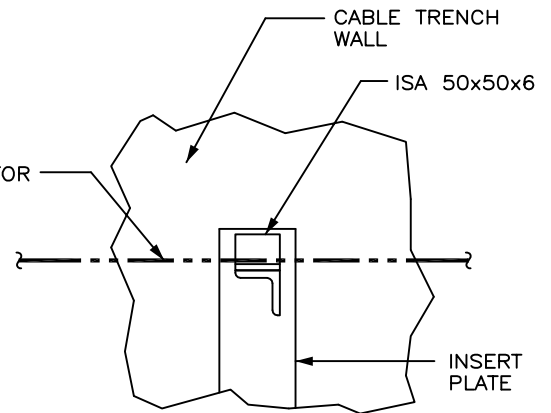

SECTION A - A

NOTES :-

1. MS FLAT SHALL RUN ON TOP TIER ALL ALONG THE CABLE TRENCHES & WELDED TO EACH OF THE RACKS.
2. MS FLAT SHALL BE EARTHED AT 30M INTERVAL AND ALSO AT BOTH ENDS.

RELEASED FOR CONTRUCTION

**POWER GRID CORPORATION
OF INDIA LIMITED**
(A Government of India Enterprise)



**PROJECT :- TECHNICAL SPECIFICATION-
SWITCHYARD ERECTION**

TITLE:- STANDARD EARTHING DETAILS

<i>KK Parhar</i>	<i>KK Parhar</i>	Dec-2013	Drawing No.:
CKD BY	PRPD BY	Date	C/ENG/STD/EARTHINGS/09 SHEET # 23

EARTHING OF GATES

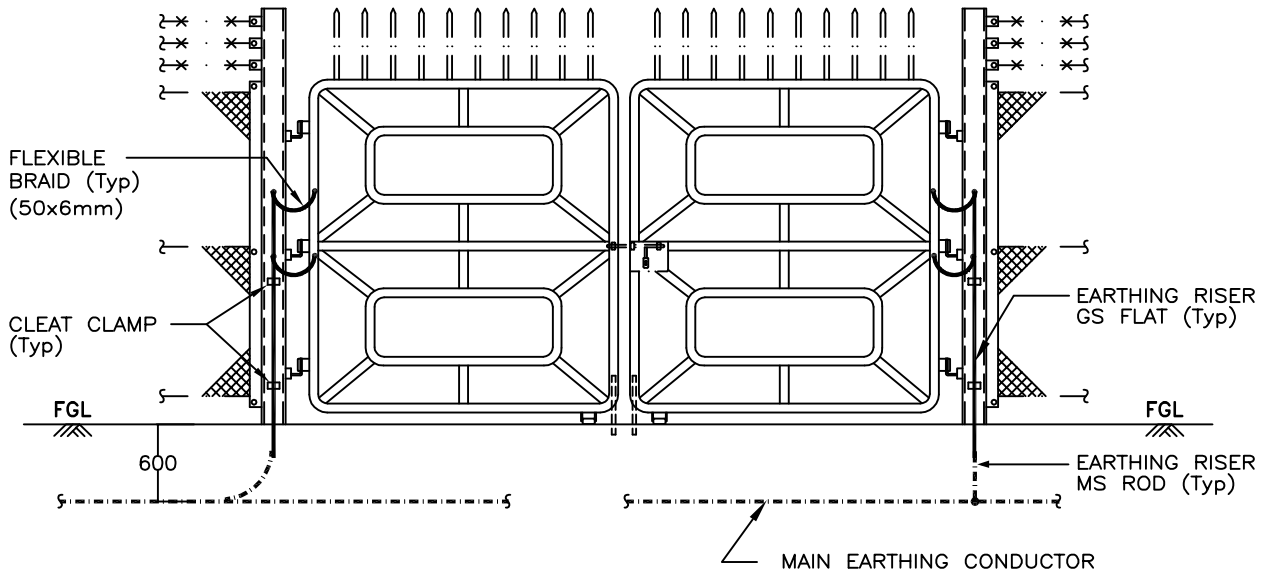

MAIN GATE

LEGEND

- 40mm ϕ MS ROD
- 75 x 12 mm GS FLAT
- 50 x 6 mm MS FLAT

NOTES :-

	FENCE POST	MAIN GATE
1 . No. OF RISERS REQUIRED	1	2
2 . No. OF FLEXIBLE BRAID	-	4
3. ALL GATES & EVERY ALTERNATE FENCE SHALL BE CONNECTED TO EARTHING GRID.		

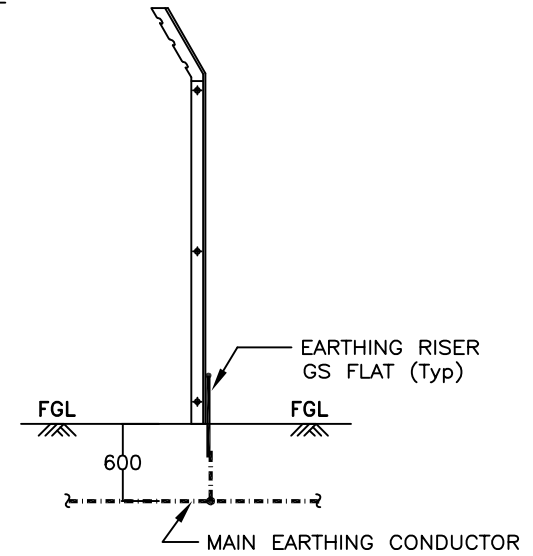

FENCE POST (ALTERNATE FENCE POST)

RELEASED FOR CONTRUCTION

POWER GRID CORPORATION
OF INDIA LIMITED
(A Government of India Enterprise)



PROJECT :- TECHNICAL SPECIFICATION-
SWITCHYARD ERECTION

TITLE:- STANDARD EARTHING DETAILS

<i>KK Parhar</i>	<i>KK Parhar</i>	Dec-2013	Drawing No.: C/ENG/STD/EARTHINGS/09 SHEET # 24
CKD BY	PRPD BY	Date	

EARTHING OF LT TRANSFORMER

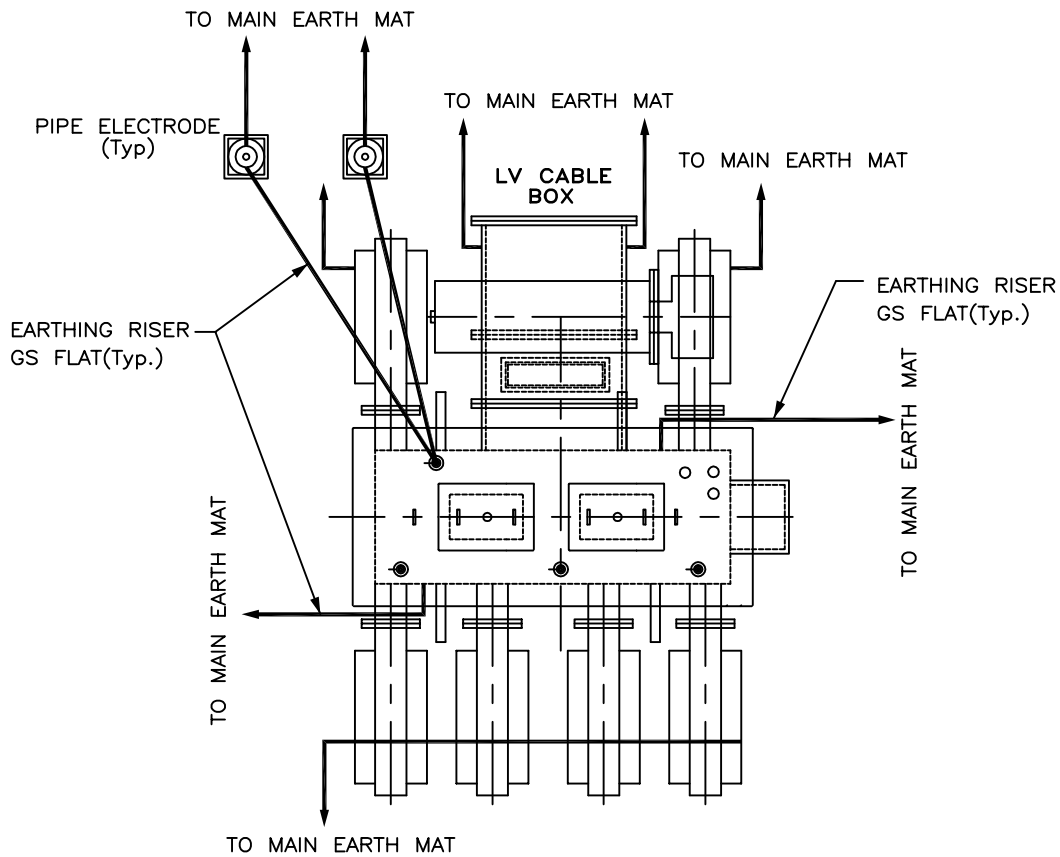

PLAN

LEGEND

— · — · — · —	40mm ϕ MS ROD
—————	75 x 12 mm GS FLAT
- - - - -	50 x 6 mm GS FLAT

NOTES :-

1. No. OF RISERS FOR MAIN TANK & T.M. MAR. BOX = 4 Nos.
2. No. OF RISERS FOR LV CABLE BOX & RADIATOR = 4 Nos.
3. No. OF RISERS FOR PIPE ELECTRODE = 2 Nos.
4. No. OF PIPE ELECTRODES REQUIRED = 2 Nos.

RELEASED FOR CONTRUCTION

**POWER GRID CORPORATION
OF INDIA LIMITED**
(A Government of India Enterprise)



**PROJECT :- TECHNICAL SPECIFICATION-
SWITCHYARD ERECTION**

TITLE:- STANDARD EARTHING DETAILS

<i>KK Parshar</i>	<i>KK Parshar</i>	Dec-2013	Drawing No.:
CKD BY	PRPD BY	Date	C/ENG/STD/EARTHINGS/09 SHEET # 25

EARTHING OF LT TRANSFORMER

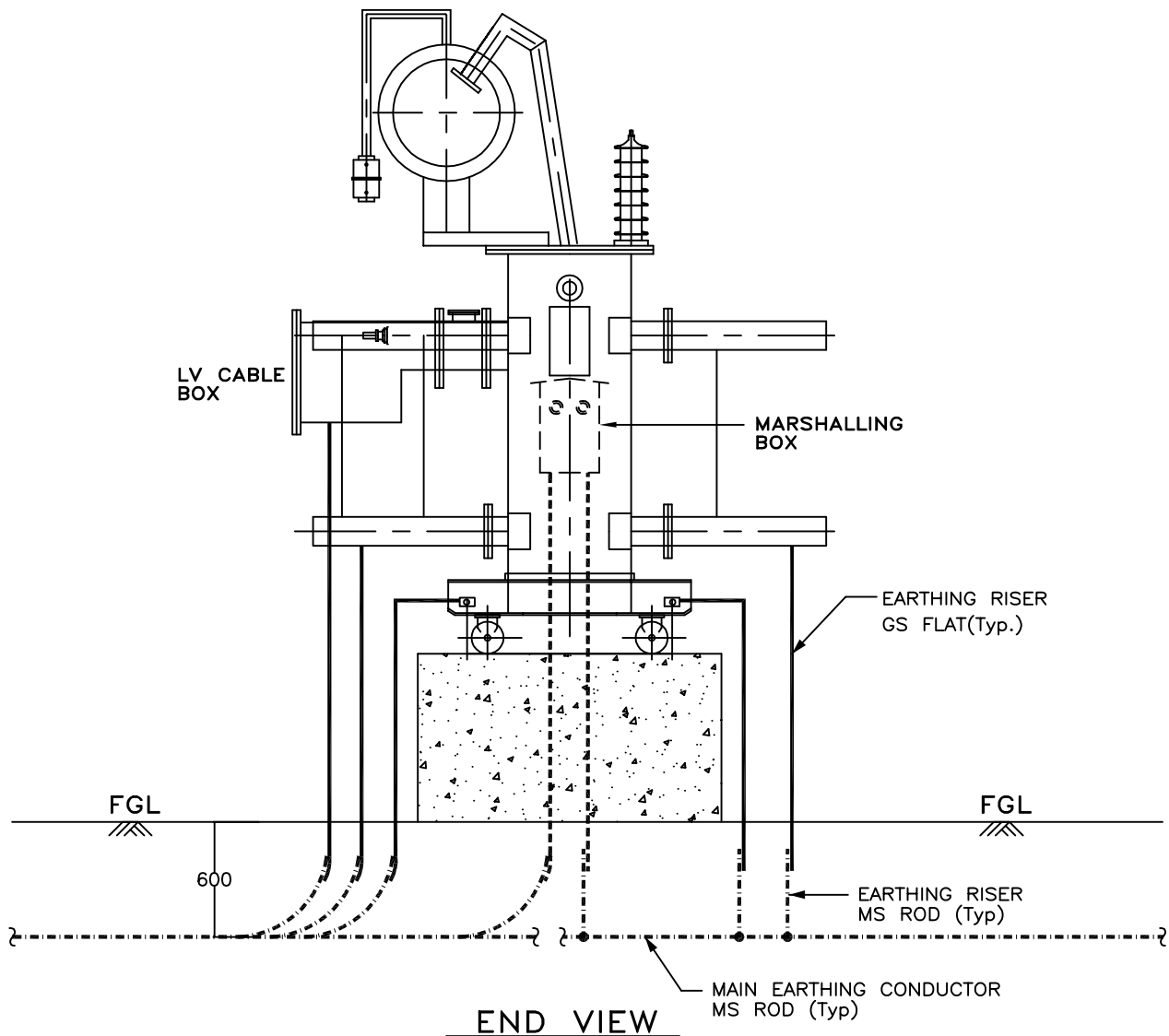

RELEASED FOR CONTRUCTION

**POWER GRID CORPORATION
OF INDIA LIMITED**
(A Government of India Enterprise)



**PROJECT :- TECHNICAL SPECIFICATION-
SWITCHYARD ERECTION**

TITLE:- STANDARD EARTHING DETAILS

<i>KK Parhar</i>	<i>KK Parhar</i>	Dec-2013	Drawing No.: C/ENG/STD/EARTHINGS/09 SHEET # 26
CKD BY	PRPD BY	Date	

EARTHING OF PYLON SUPPORTS

Pylon supports shall be grounded through 50x6mm GI flat to the ring around the Pylon supports of 75x12mm GI flat which in turn is connected to the main grid (40 mm dia MS rod) at 2 to 3 points as available.

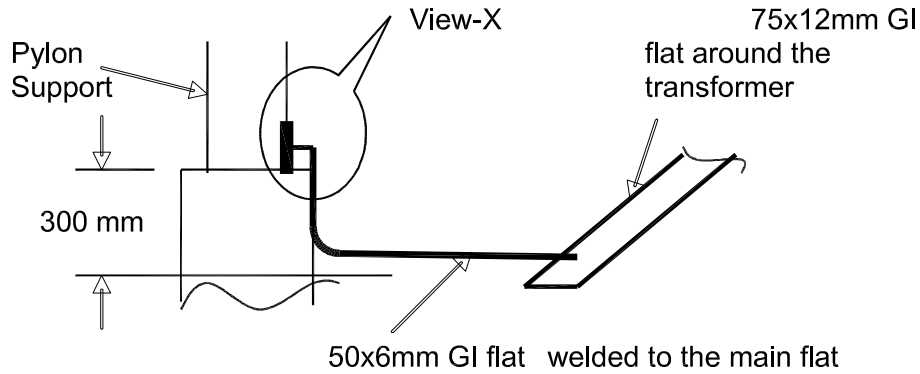

Fig.- Elevation (Earthing of Pylon Supports)

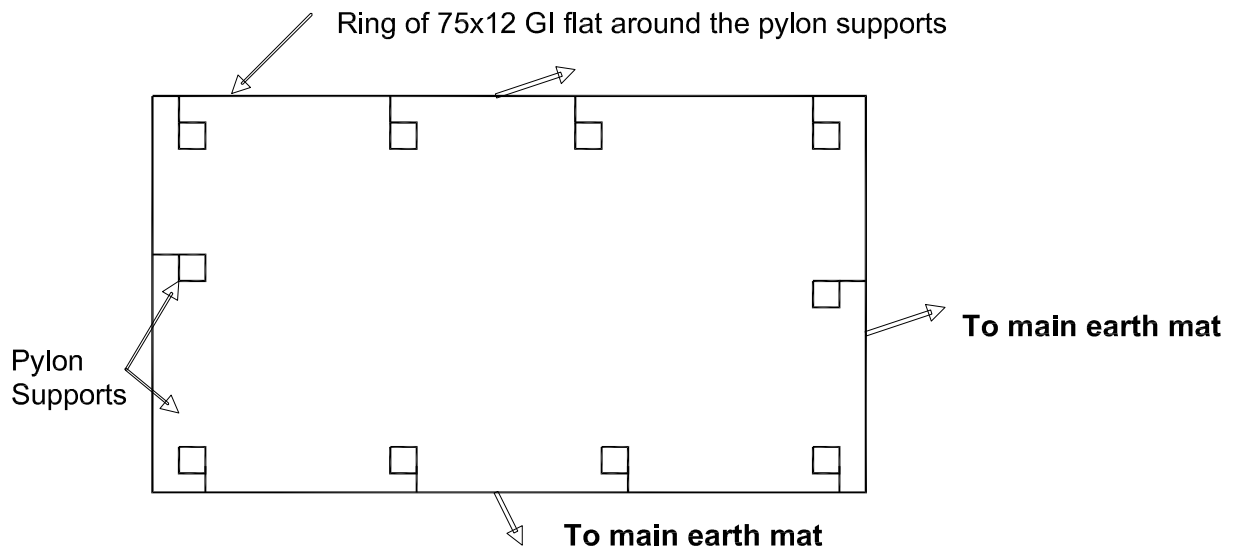



Fig.- Layout (Earthing of Pylon Supports)

RELEASED FOR CONTRUCTION

POWER GRID CORPORATION OF INDIA LIMITED <small>(A Government of India Enterprise)</small>			 पावरग्रिड
PROJECT :- TECHNICAL SPECIFICATION- SWITCHYARD ERECTION			
TITLE:- STANDARD EARTHING DETAILS			
<i>HN Pashar</i>	<i>HN Pashar</i>	Dec-2013	Drawing No.: C/ENG/STD/EARTHINGS/09 SHEET # 27
CKD BY	PRPD BY	Date	

EARTHING OF HYDRANT/ HVW SPRAY PIPING

These pipes shall be grounded at pump house through 50x6mm GI flat connected to the main flat, 75x12mm running around the room.

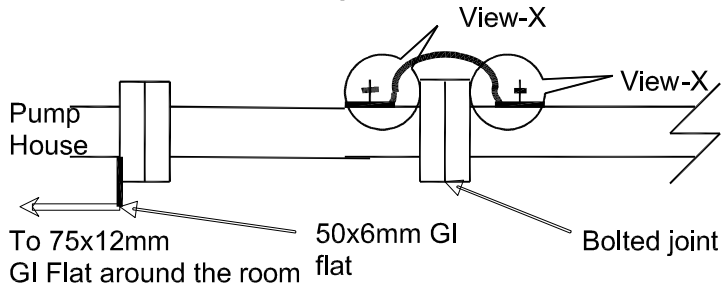

Fig.-Earthing of Hydrant / HVW Spray Piping

EARTHING OF HYDRANT POST/ HOSE BOX

A bolt shall be welded to these structures at the time of installation which can be used to connect them to the nearest riser or main 75x12mm GI flat through 50x6mm GI flat.

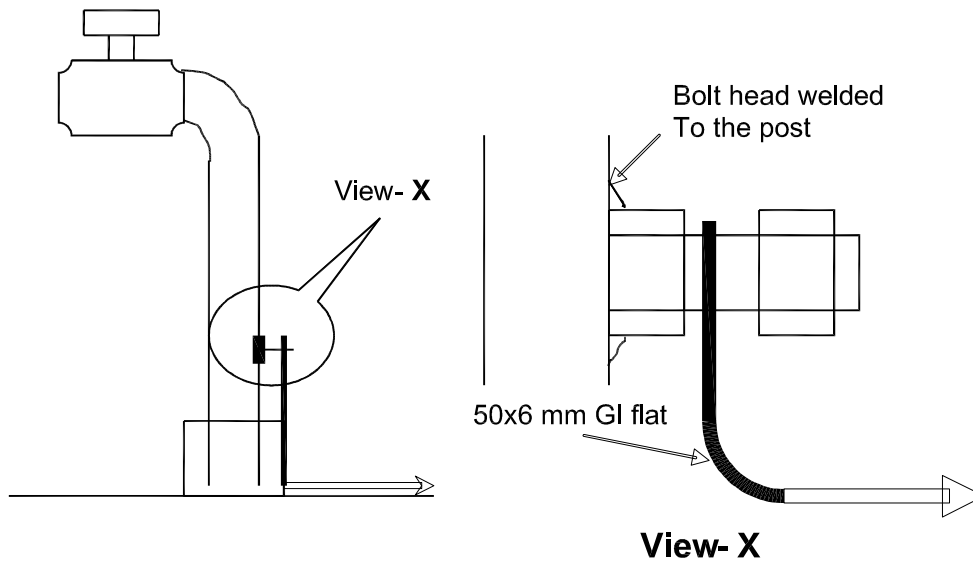



Fig.- Earthing of hydrant box / hose box

RELEASED FOR CONTRUCTION

POWER GRID CORPORATION OF INDIA LIMITED (A Government of India Enterprise)			 पावरग्रिड
PROJECT :- TECHNICAL SPECIFICATION- SWITCHYARD ERECTION			
TITLE:- STANDARD EARTHING DETAILS			
<i>HKPashar</i>	<i>HKPashar</i>	Dec-2013	Drawing No.: C/ENG/STD/EARTHINGS/09 SHEET # 28
CKD BY	PRPD BY	Date	